

S975 SERVICE MANUAL

MODEL YEAR 2025 REV. A

FOR MORE INFORMATION CALL 1.800.883.9790 or WWW.SCHERERINC.COM

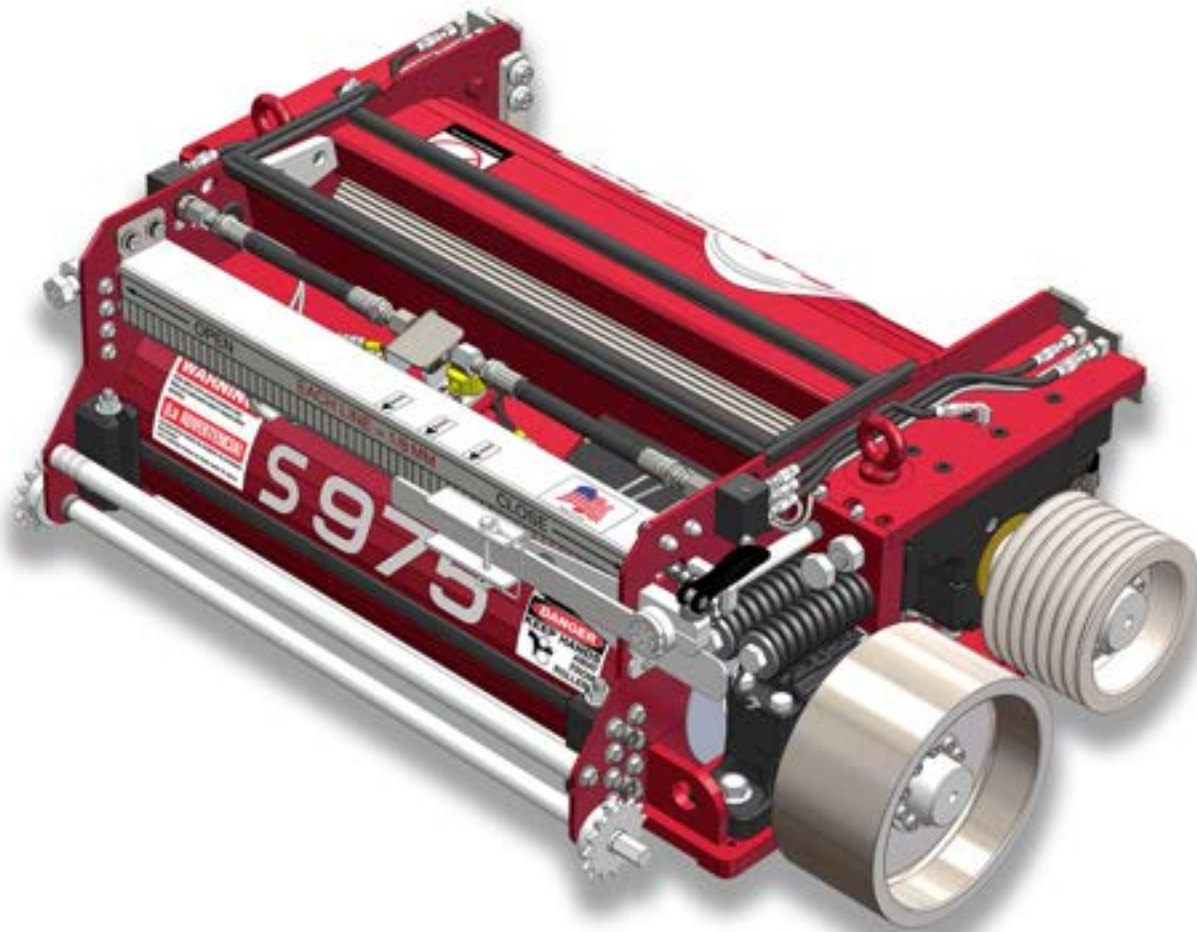

Index

<u>Section</u>	<u>Page #</u>	<u>Section</u>	<u>Page #</u>
Contact Page	1	Roll Parts	58
Service New Product Warranty	2	Roll Housing Parts	59
Safety	4	Bulb Seal Replacement Kit	60
498 & Newer Schermist® Installation	6	Cheek Plate Replacement Kit	61
494-497 Newer Schermist® Installation	8	Schermist® Parts List	62
Schermist® Upgrade Kit	10	Schermist® Head Parts List	67
Schermist® Operation	11	Grease/Manual Lubrication Parts	68
Scherer Grease KP Installation	12	Manual Lubrication Parts List	69
Kernel Processor Installation	13	7 Groove Drive Kit Installation	70
Taper Lock Installation	14	6 Groove Drive Kit Installation	71
Sentry 4.0 Installation	15	7 Groove Air Drive Parts	72
Sentry 4.0 Operation	18	6 Groove Air Drive Parts	77
Sentry 4.0 Parts	28	7 Groove Accelerator Pulley	81
Belt Options	29	6 Groove Accelerator Pulley	82
7 Groove Pulley Options	30	Decal Layout	83
6 Groove Pulley Options	31	Scherer Equipped	84
Roll Gap Adjustment Instructions	32	Accessory Parts	85
Maintenance Intervals	33		
Roll Change Instructions	35		
Processor Opening Instructions	36		
End of Year Roll Maintenance	37		
Roll Bearing Removal & Installation	40		
Schermist® Head Rebuild	42		
Important Torque Specifications	43		
Top Frame Parts	44		
Top Frame Parts List	45		
Top Frame Adjustment Parts	46		
Top Frame Adjustment Parts List	47		
Bottom Frame Parts	48		
Bottom Frame Parts List	49		
Bottom Latch Block Parts	50		
Slide Parts	51		
Temperature Wiring Parts	52		
Air Lubrication System Parts	53		
Grease & Oil Lubrication Kit	54		
Extended Sentry Parts	55		
Complete Roll Options	56		
No Housing Roll Options	57		



U.S. Patent No. 7,681,384
Others Patents Applied for
Foreign Patents Applied for

4940 W Foundation Court Sioux Falls, SD 57107

1-800-883-9790

(605) 368-2659

Fax: (605) 368-9737

Service New Product Warranty

LIMITED WARRANTY ON NEW SCHERER KERNEL PROCESSORS AND PROCESSOR ROLLS

Scherer, Inc. ("Scherer") will provide for repairs or replacement, at its option during the warranty period of each new Scherer Kernel Processors and/or new Scherer Kernel Processor Rolls in accordance with the following terms, conditions, and limitations.

WHAT IS COVERED

WARRANTY APPLIES – This warranty is for new Scherer Kernel Processors and/or new Scherer Kernel Processor Rolls installed in a Claas® Forage Harvester by a certified technician, and is provided to the original and any subsequent owner(s) of the Claas® Forage Harvester during the warranty provision.

REPAIRS COVERED – The warranty covers repairs or replacement, at Scherer's option, to correct any malfunction resulting from defects in the design, material or workmanship occurring during the warranty period. Needed repairs or replacements will be performed using the method Scherer determines most appropriate under the circumstances.

OBTAINING REPAIRS – To obtain warranty repairs, contact Scherer at portal.schererinc.com.

WARRANTY PERIOD – The warranty period for all coverages shall begin on the date installed by the dealer and shall continue for twelve months.

WHAT IS NOT COVERED

DAMAGE DUE TO ACCIDENT, MISUSE, or ALTERATION – Defects and damage caused as a result of any of the following are not covered:

Flood, Collision, Fire, Theft, Vandalism, Riot, Explosion, Acts of Terrorism;

- Misuse of the Forage Harvester;
- Installation into unapproved applications and installations;
- Alterations or modification of the Kernel Processor, Processor Rolls, or Forage Harvester;
- Anything other than defects in the Scherer Kernel Processor or Processor Roll design, materials, or workmanship.

DAMAGE CAUSED by LACK of MAINTENANCE – Defects and damage caused by the owner's failure to follow the recommendations of the maintenance schedule provided by Scherer.

MAINTENANCE – Normal Maintenance (such as adjustments after initial installation and use as set out in the owner's manual; periodic maintenance as set out in the owner's manual based upon hours of use, and **END OF SEASON** maintenance as set out in the owner's manual) is not covered and is the owner's responsibility.

USE OF OTHER THAN GENUINE SCHERER PARTS – Defects and damage caused by the use of parts that are not genuine Scherer parts are not covered.

EXTRA EXPENSES – Economic loss and extra expenses are not covered. Examples include but are not limited to: loss of Forage Harvester use, inconvenience, lost profits, loss of time, any travel costs.

OTHER TERMS APPLICABLE TO CONSUMERS AS DEFINED BY THE MAGNUSON -MOSS WARRANTY ACT

This warranty gives you specific legal rights and you may also have other rights which vary from state to state.

Scherer Inc. does not authorize any person to create for it any other obligation or liability in connection with these Kernel Processors and Processor Rolls. ANY IMPLIED WARRANTY OF MERCHANTABILITY OR FITNESS FOR A PARTICULAR PURPOSE APPLICABLE TO THESE TRANSMISSIONS IS LIMITED IN DURATION TO THE DURATION OF THIS WRITTEN WARRANTY. PERFORMANCE OF REPAIRS AND NEEDED ADJUSTMENTS IS THE EXCLUSIVE REMEDY UNDER THIS WRITTEN WARRANTY OR ANY IMPLIED WARRANTY. SCHERER INC. SHALL NOT BE LIABLE FOR INCIDENTAL OR CONSEQUENTIAL DAMAGES (SUCH AS, BUT NOT LIMITED TO, LOST PROFITS OR RENTAL EXPENSES) RESULTING FROM THE BREACH OF THIS WRITTEN WARRANTY OR ANY IMPLIED WARRANTY.**

** Some states do not allow limitations on how long an implied warranty will last or the exclusion or limitation of incidental or consequential damages, so the above limitations or exclusions may not apply to you.

OTHER TERMS APPLICABLE TO OTHER END-USERS

THIS WARRANTY IS THE ONLY WARRANTY APPLICABLE TO THE SCHERER KERNEL PROCESSORS AND PROCESSOR ROLLS AND IS EXPRESSLY IN LIEU OF ANY OTHER WARRANTIES, EXPRESSED OR IMPLIED, INCLUDING IMPLIED WARRANTY OF MERCHANTABILITY OR FITNESS FOR A PARTICULAR PURPOSE. SCHERER INC. DOES NOT AUTHORIZE ANY PERSON TO CREATE FOR IT ANY OTHER OBLIGATION OR LIABILITY IN CONNECTION WITH SUCH KERNEL PROCESSORS OR PROCESSOR ROLLS. SCHERER INC. SHALL NOT BE LIABLE FOR INCIDENTAL OR CONSEQUENTIAL DAMAGES RESULTING FROM BREACH OF THIS WARRANTY OR ANY IMPLIED WARRANTY.

Scherer Protection Extension

Effective 11/30/21 Extend the standard 1-year Limited Warranty up to +4 years (5 years total). Scherer Protection Extension must be purchased at same time the KP order is placed. All Scherer Protection Extension Warranties need to be filed on the Dealer Portal. Annual inspection to be completed by the Dealer & filed under the warranty section of Dealer Portal. Failure to file annual inspection may result in rejected warranty claims. Scherer Protection Extension is not retroactive to any kernel processors that have already been in service. Scherer Protection Extension is transferrable to 2nd owner. Unlimited acres/hours/tons, No deductible. Scherer does not warranty normal wear items, including but not limited to, Cheek plates, bulb seals, rolls, felt seals, KP belt, pulleys, or taper hub assemblies. Scherer does not warranty normal maintenance items on KP or air system components, including but not limited to, Filters, gaskets.

QUESTIONS

If you have any questions regarding this warranty or the performance of warranty obligations, you may contact Scherer, Inc. thru the dealer portal: portal.schererinc.com.

Safety

Warning: Read and understand all of the following safety messages. Be familiar with general operating and maintenance instructions. Be sure to lock out the power supply before performing any maintenance and adjustments. The person performing the maintenance should be the only one with the ignition key for the machine.

General Safety Practices,

Always observe safe operating practices around machinery. Most accidents are the result of carelessness or negligence. All rotating machinery is potentially dangerous. Guard and operate rotating machinery as required by applicable laws, regulations and good standard safety practices.

Before doing any maintenance on engine driven machinery, turn off ignition. Remember, the person doing the maintenance or adjustment should be the only one with the ignition key.

Use the proper tools for each maintenance task. Keep lifting equipment in good condition and **DO NOT** stand under objects being lifted. Keep a clean work area to ensure workers have good footing.

Inlet/Discharge Opening Hazard

The processor has an inlet and discharge opening. Injury will result if persons or objects fall into the inlet or discharge. A serious hazard exists if a person places their arm or any object into the inlet or discharge area of the processor. **DO NOT** remove protective guards.

Belt Drive Hazard

Be sure that the belt guards are in place before operating the processor.

Rotating Rolls Hazard

The rotating rolls are a severe hazard. The rolls turn at high speeds and operate with a grinding action that will pull objects between the rolls. Keep all body parts and all objects out of this area. **DO NOT** insert any part of your body or any tool into the roller area.

Eye Protection

Wear approved safety glasses when working around all equipment. Moving machinery can throw objects unexpectedly.

Head Protection

Wear an approved hard hat while installing the processor into and out of the machine. Falling objects or low overhead can cause severe injury while installing or removing the processor from the machine.

Hearing Protection

Under normal operating conditions, this machine does not produce hazardous noise. However, the machine itself is very noisy when operated at full throttle. Wear approved hearing protection as needed when working around equipment.

498 & Newer Schermist® Installation



Image 1



Image 2

Locate 90° fitting under the left-hand hood (Image 1). Remove the 90° fitting, and replace it with the “T” fitting (SPL10111). Take the 90° fitting that was removed and install it on the open end of the “T”. Install the adapter fitting (HPD1423), the union (HPD1422), and then the push-lock fitting (OM1025). See image 2 for this process. From there run a short piece of supplied plastic airline (D1348) and install the ¼ turn valve (HPD1359). This is seen in image 3.

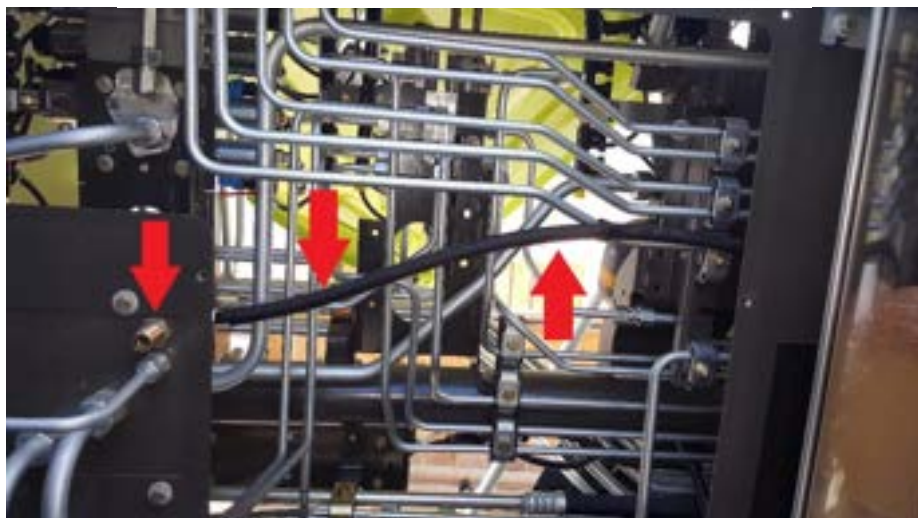

Image 3

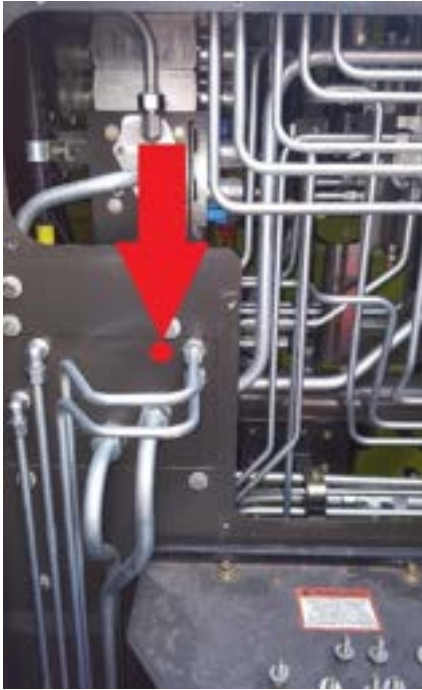

Image 1



Image 2

Remove the service panel, in the KP compartment. Drill a hole and mount the threaded bulkhead fitting (HPD1425) as shown (Image 1). Install the 90° fitting (HPD1420) on both sides of the bulkhead fitting. Take the supplied air-line and route it from the 1/4 turn valve to the 90° fitting on the back side of the bulkhead. (Image 2) **NOTE: If the machine has diff lock you can install the bulkhead back 2" to clear the added air-line.**

Image 3



With the service panel off, drill and mount the Schermist® and coalescing filter assembly. Bolt the service panel back onto the machine. Run a small piece of air-line (D1348) from the 90° fitting on the bulkhead to the coalescing filter. Run another section of line from the filter to the Schermist® assembly (Image 3). The air shutoff valve (HPD1359) can also be installed between the coalescing filter and oil tank. Seen above with the arrow.

494 - 497 Schermist® Installation



Connect supply hose to the CLAAS air hose as shown above, using provided "T" fitting (HPD1349). You will have to cut $\frac{3}{4}$ " out of the CLAAS hose in order to install "T" fitting. Route supply hose up and between cab and chute using provided wire-ties in order to connect to the coalescing filter .

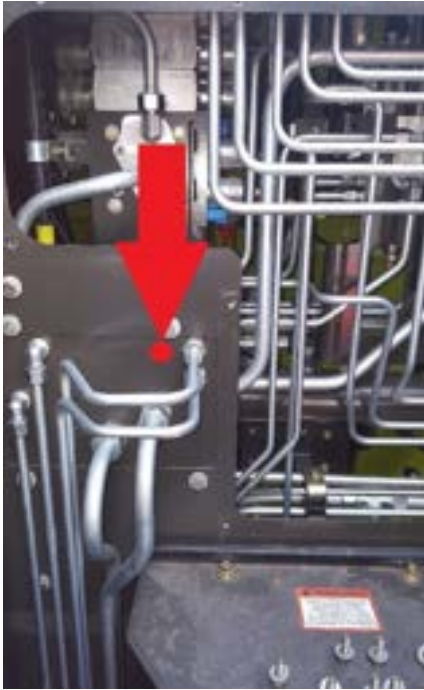

Image 1



Image 2

Remove the service panel, in the KP compartment. Drill a hole and mount the threaded bulkhead fitting (HPD1425) as shown (Image 1). Install the 90° fitting (HPD1420) on both sides of the bulkhead fitting. Take the supplied air-line and route it from the 1/4 turn valve to the 90° fitting on the back side of the bulkhead. (Image 2) **NOTE: If the machine has diff lock you can install the bulkhead back 2" to clear the added air-line.**

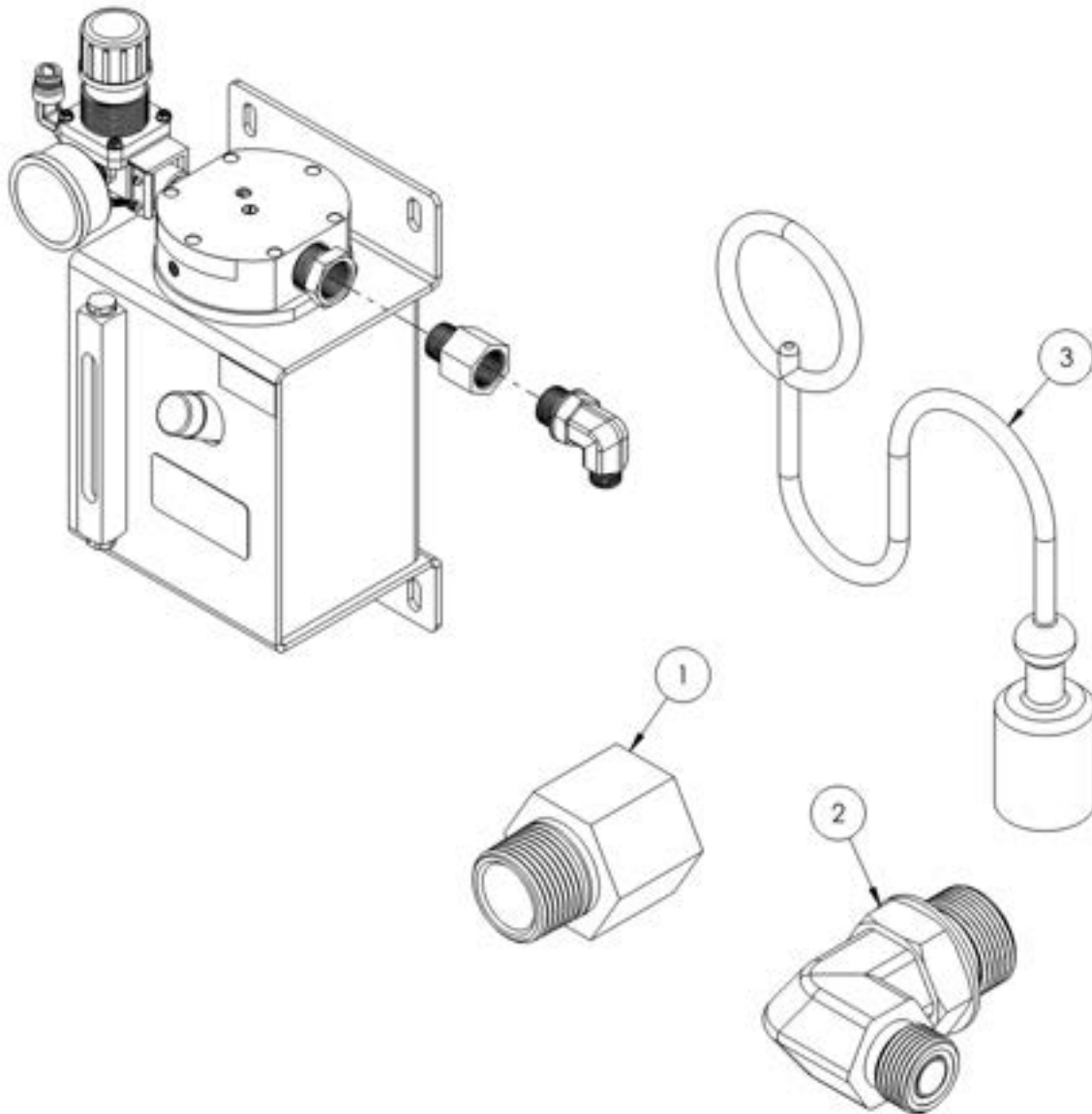

Image 3

With the service panel off, drill and mount the Schermist® and coalescing filter assembly. Bolt the service panel back onto the machine. Run a small piece of air-line (D1348) from the 90° fitting on the bulkhead to the coalescing filter. Run another section of line from the filter to the Schermist® assembly (Image 3).

Converting Standard Oiler to Metric Oiler

ASM10378



ITEM NO.	PART NUMBER	DESCRIPTION	QTY.
1	OM1030	STRAIGHT ADAPTER	1
2	OM1034	90 DEGREE ADAPTER FITTING	1
3	SPL10027	FEMALE CAP	1

ASM10378 is only needed when upgrading a KP to a newer model that utilizes metric fittings. When upgrading from a HDS, HP, HPM-60, or HO to a S series KP this upgrade kit is needed.

Schermist® Operation

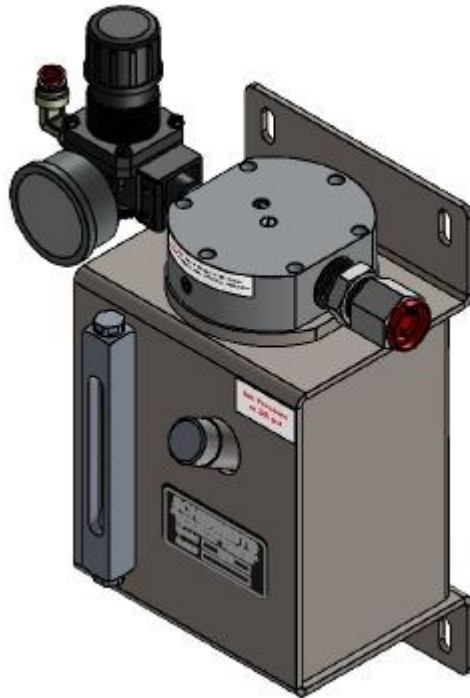

- Make sure to maintain an air pressure of 35psi at the Schermist® regulator.
- Oil fill is the plug located on the front of the Schermist® reservoir.
- The air and oil screws on top of the Schermist® head are preset at the factory. To maintain ideal operating conditions **DO NOT ADJUST THESE SCREWS.**
- Fill with oil until the oil level matches the full mark on the sight glass. **SCHERMIST® WILL NOT FUNCTION PROPERLY IF IT IS FILLED ABOVE THE FULL MARK!!**
- Only use Scherer KP oil. It is available from dealer in 1 gallon, and 5 gallon quantities.
- In very wet corn conditions, we recommend changing the oil in the bearings every two weeks and at the end of the season. To change the oil, remove the most convenient plug and drain. Refill the bearing housing with .50 oz. of fresh oil.
- **At the end of season, remove all water from regulator and air lines to prevent damage from freezing.**
- When removing the kernel processor, disconnect the hose from the Schermist® exhaust port and plug the end of the hose to keep dirt out. Also cap off the Schermist® exhaust port and turn off the air supply to the Schermist® .
- **THE SCHERMIST® SYSTEM SHOULD NOT BE PRESSURIZED IF THE EXHAUST PORT IS CAPPED OFF.**

Scherer Grease KP Installation

When installing a Scherer grease KP, the lubrication line attached to the KP (ASM10179—seen on page 44) can be hooked up directly to the forage harvesters greaser. The line on the KP connects to the factory grease KP hook up. This can be seen in the images below.



Kernel Processor Installation

1.) Before lifting the processor into place in the machine, ensure that the latch blocks and hinges are tight. Never stand under the processor when it is lifted overhead.

2.) You can install the processor from the side or from the top. For ease of installation, remove the crossbar support that is bolted to the floor and to the discharge chute. Place processor in the machine. If you have removed the crossbar support, install it back into place at this time.



Image 1

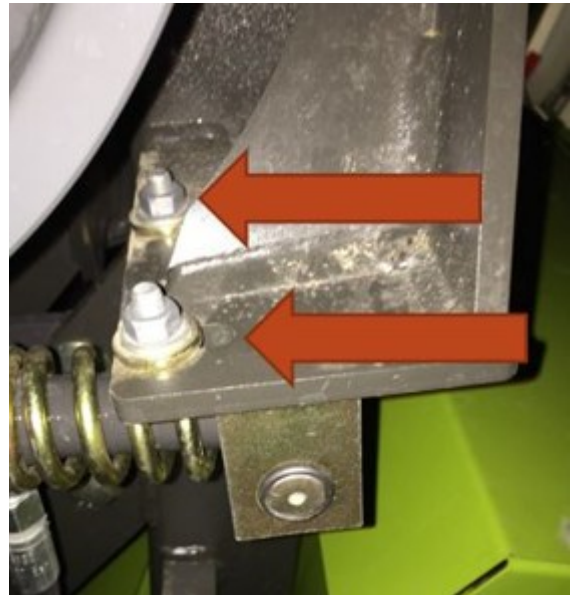

Image 2

4.) Check fitment of processor in relationship to the top edge of the transition chute wear liner (red circle - image 1 above) on both sides. Grind edges if necessary to allow processor to slide into position. Check clearance when transition chute is in operating position. Carriage bolts from the bottom of the accelerator can be turned around to create more clearance. Make sure the rolls spin free when the engine is running, and belt is off.

5.) Check clearance for processor ledge to slide under bolt head on both sides (red arrows - image 1 above). **Grind bottom of the head of the socket head cap screw if necessary.** Also be aware of the two different hole positions. This needs to line up the grass chute. The Scherer KP also has an adaptor on the KP frame to help with this.

6.) To ensure proper belt tension with your new kernel processor loosen the two bolts on the hydraulic tension arm and slide the tension arm towards the back of the machine. Once the arm is slid back and into position tighten the bolts. See image 2 above for reference.

7.) With the processor ahead and secured into the operating position, you now need to check proper pulley alignment. Do this by laying a straight edge along the main drive pulley and along the processor pulleys. A laser alignment tool (A0011) can be purchased to ensure precise alignment. This needs to be done on all installations, new and used KP's. If any adjustment needs to be done, please refer to keyless taper lock torque specifications on the next page.

B-LOC® Keyless Bushings provide a high capacity, zero-backlash shaft/hub or coupling connection by means of a mechanical interference fit. Please follow these **INSTALLATION AND REMOVAL INSTRUCTIONS** carefully to ensure proper performance of this **B-LOC®** unit.

WARNING	
When installing or removing B-LOC® products, always adhere to the following safety standards:	
1.	Be sure that the system is de-energized using proper lockout/tagout procedures
2.	Wear proper personal protective equipment.

INSTALLATION

(Refer to Figure 1)

B-LOC® Series B103 and B106 Keyless Bushings are supplied lightly oiled and ready for installation. They are self-centering and fit straight-thru hub bores. Note that Series B103 units permit axial hub movement during installation. In contrast, the extended flange on Series B106 units results in an axially fixed hub position during assembly. When reinstalling a used unit, make sure that all slits are aligned. The frictional torque capacity of these devices is based on a coefficient of friction of 0.12 for lightly oiled screw, taper, shaft and bore contact areas.

Therefore, it is important *not* to use Molybdenum Disulfide (e.g., Molykote, Never-Seeze or similar lubricants) in any Keyless Bushing installation.

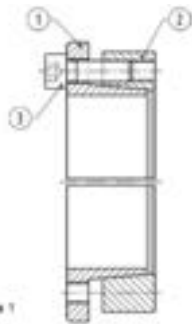

1. Make sure that locking screw, taper, shaft and bore contact areas are clean and lightly oiled with a light machine oil and that all collar slits are aligned.
2. Loosen all locking screws by a minimum of four (4) turns and transfer at least three (3) screws into push-off threads in order to keep Parts 1 and 2 separated during assembly (see Figure 2).
3. After inserting Keyless Bushing into hub bore, relocate locking screws used for separating Parts 1 and 2.
4. Hand tighten locking screws and confirm that collar Item 1 is parallel and in full contact with face of part to be attached to shaft.
5. Use torque wrench and set it approximately 5% higher than specified tightening torque (Ma). Tighten locking screws in either a clockwise or counterclockwise sequence (it is not necessary to tighten in a diametrically opposite pattern), using only 1/4 (i.e., 90°) turns for several passes until 1/4 turns can no longer be achieved.
6. Continue to apply over torque for 1 to 2 more passes. This is required to compensate for a system-related relaxation of locking screws since tightening of a given screw will always relax adjacent screws. Without over torquing, an infinite number of passes would be needed to reach specified tightening torque.
7. Reset torque wrench to specified torque (Ma) and check all locking screws. No screw should turn at this point, otherwise repeat Steps 6 and 7.

NOTE: 1. It is not necessary to re-check tightening torque after equipment has been in operation.

2. The torque capacity of these units can be increased by approximately 25% by thoroughly cleaning the shaft and Keyless Bushing bore of any lubricant. In applications subject to extreme corrosion, the slits in all collars should be sealed with a suitable caulking compound or equivalent. Likewise, push-off threads should be protected from corrosion.

INSTALLATION OF B-LOC® KEYLESS BUSHING OVER SHAFT KEYWAYS

The Keyless Bushing should be positioned so that slits in Keyless Bushing collars that contact the shaft are located approximately opposite the keyway. In addition, a locking screw should be centered directly over the keyway.

When tightening locking screws, it is important to follow the installation procedure outlined above, which specifies equal 1/4 turns of each locking screw. Failure to follow these instructions could result in excessive tightening of the screw over the keyway, possibly causing permanent deformation of the Keyless Bushing collars.

REMOVAL

(Refer to Figure 2)

Prior to initiating the following removal procedure, check to ensure that no torque or thrust loads are acting on the Keyless Bushing, shaft or any mounted components.

IMPORTANT! Make sure ends of locking screws used for removal are

1. Check to ensure that axial movement of collars - necessary for release of connection - is not restricted. Likewise, ensure that push-off threads are in good condition.
2. Relax all locking screws by approx. four (4) complete turns and transfer screws to all push-off threads located in flange of collar Item 1.
3. Release connection by evenly tightening all push-off screws (not exceeding 1/4 turns) in a diametrically opposite sequence.

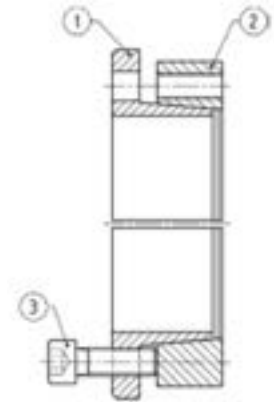

ground flat and are slightly chamfered to prevent damage to screw and collar threads during push-off.

LOCKING SCREW SIZES AND SPECIFIED TIGHTENING TORQUE Ma						
Metric Series	Inch Series	Tightening Torque Ma (ft lb)		Screw Size	Hex Key Size (mm)	
		B106	B103			
20 x 47 to 40 x 65	3/4 to 1-1/2	12	10	M6	5	
45 x 75 to 65 x 95	1-5/8 to 2-9/16	30	25	M8	6	
70 x 110 to 95 x 135	2-11/16 to 3-3/4	60	50	M10	8	
100 x 145 to 120 x 165	3-15/16 to 4-3/4	105	90	M12	10	
130 x 180 to 200 x 260	4-15/16 to 8	166	135	M14	12	
220 x 285 to 260 x 325		257	219	M16	14	
280 x 355 to 300 x 375		350	290	M18	14	
320 x 405 to 340 x 425		500	420	M20	17	
360 x 455 to 400 x 495		675	560	M22	17	

Sentry 4.0 Installation

Start by taking the multi-box and place it on the inside of the right hand exterior panel (Image 1). From the harness (SPL10256), there is a cord labeled display. Take this cable and route it from the multi-box through the hole in the firewall panel (Image 2).

Image 1



Image 2



Under the right hand control arm in the cab, remove the cover for the electrical cabinet (Image 1) and pull the display cable through the firewall. The power cord (SPL10255) plugs into a Deutsch connector on SPL10256. Remove one of the access plugs located under the ignition switch, and route the screen cable and power cable through the access hole (Image 2).

Image 1



Image 2



Plug the supplied power cord into the outlet above the electrical cabinet (Image 1). **Note that only one of the outlets is keyed power, the other is constant power.** Once you have everything plugged in go ahead and install the electrical cabinet cover, routing the cord through as shown (Image 2). The display cable can be routed along the rail mount. The display (SPL10253) is mounted to the rail with (SPL10288).



Sentry 4.0 Harness Layout

The Sentry 4.0 comes standard for monitoring the kernel processor bearing temperatures but also has the following capabilities.

- Remote adjustment from the cab. Only available in 1085SI model
- Temperature monitoring of the cutter & accelerator bearings
- Adjustable air dryer settings

The Sentry 4.0 harness comes ready to have any of the additional features hooked up. To add on any of the features, an operator must buy the needed cable and go into the system settings to activate the desired feature. The Sentry 4.0 harness has labeled break outs for all the features offered. The corresponding cables for these features are the following.

- Dryer - SPL10260
- Right Accelerator - SPL10230
- Left Accelerator - SPL10231
- Right/Left Cutter - SPL10232
- Remote Adjust - SPL10259



Sentry 4.0 Operation



The main page for the Sentry 4.0 can be seen above. The quadrants represent the bearing temperatures on the kernel processor.

Top Left - Front left bearing

Top Right - Front right bearing

Bottom Left - Rear left bearing

Bottom Right - Rear right bearing

The icons on the bottom of the main page from left to right represent the following: bearing alarms, air dryer, general, remote adjust, and home page. The side bar that reads GO TO EXT, will take the operator to the page that shows the extended sentry bearing temperatures.

If a sensor is **DISCONNECTED OR DAMAGED** the quadrant will be grey and not show a temperature reading like the top right quadrant above.

Sentry 4.0 Settings Page



Brightness - Adjust brightness.

General - Sub page with other selections.

System - Sub page with other selections.

Debug - Can be used to trouble shoot.

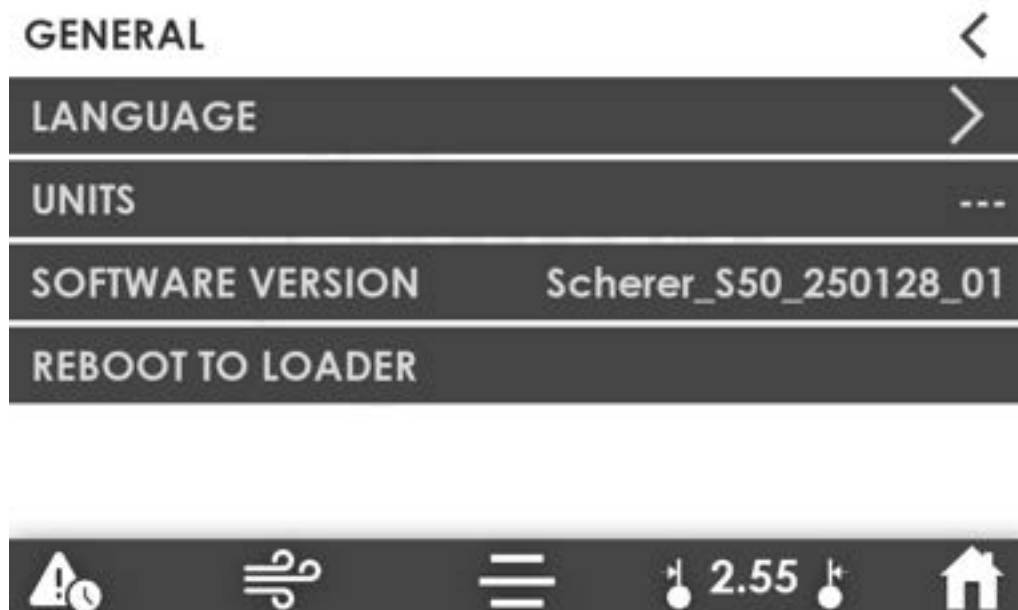

Language - Multiple languages to select from.

Units - Can choose between metric or imperial.

Software Version - This is not a selection but shows the systems software version

Reboot To Loader - This feature is utilized when updating the system with new software

System Settings

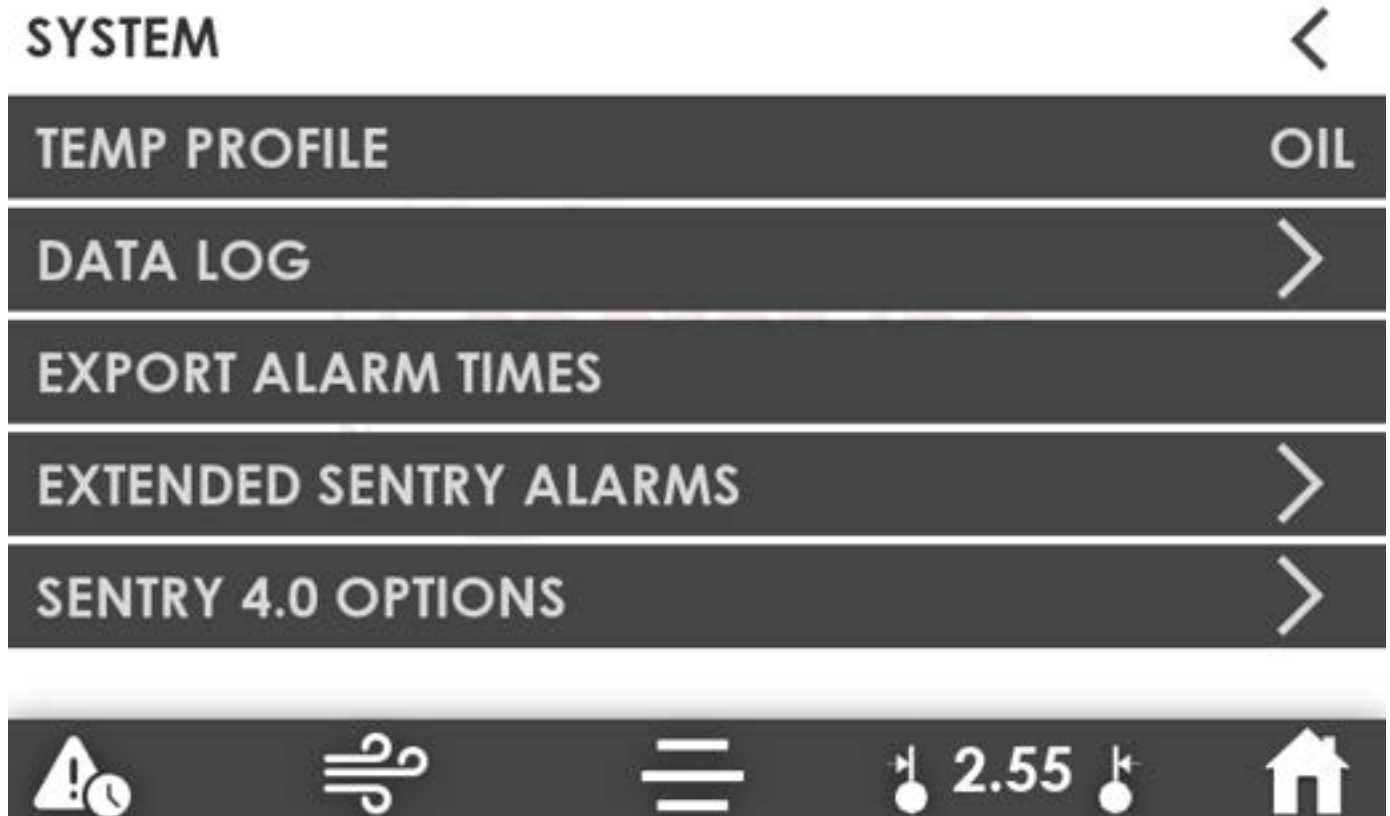

Temp Profile - Can change the system between oil & grease bearings.

Data Log - This will record the temperatures of the bearings.

Export Alarm Times - A user can export the alarms times to a USB drive.

Extended Sentry Alarms - A user has the ability to set there own alarm setpoints.

Sentry 4.0 Options - This option allows a user to decide what additional features they want active.

Sentry 4.0 Options

From the system settings menu an operator can select sentry 4.0 options and activate the features they have hooked up.

Extended Sentry - Monitors bearing temperatures for cutter & accelerator bearings.

Air Dryer - Removes moisture from the machines air system.

Remote Adjust - Give the user the ability to adjust the rolls from the cab.

Options not active



Options active



Sentry 4.0 Options

If one of the three Sentry 4.0 options icon is selected but is not activated on the Sentry 4.0 options page the following pop up will occur. This is indicating that the required components for the add on features are needed & the feature needs to be activated.

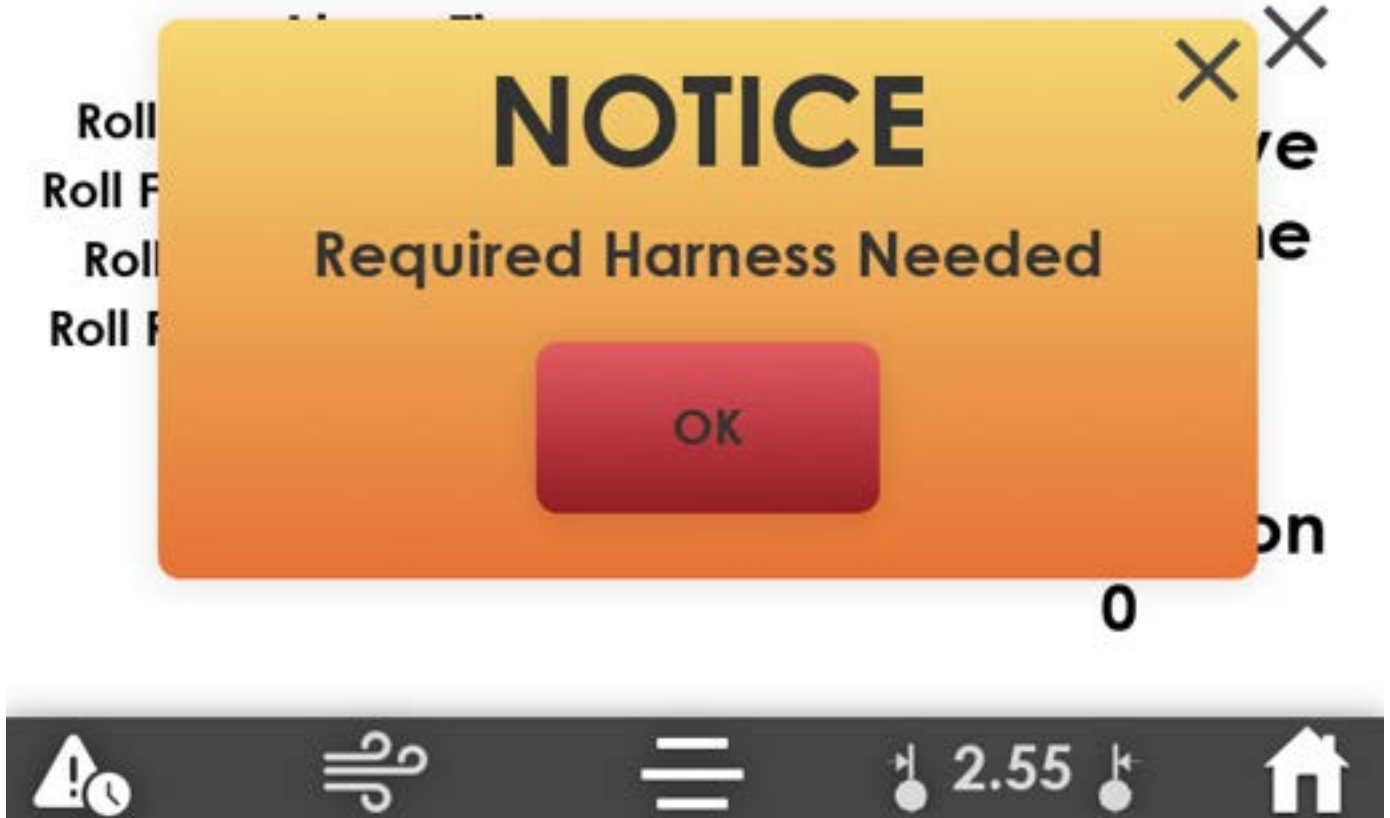

Extended Sentry



The extended sentry offers a user the ability to monitor the temperature of the cutter head and accelerator bearings. The quadrants above represent the following.

Top left - Left cutter head bearing

Top right - Right cutter head bearing

Bottom left - Left accelerator bearing

Bottom right - Right accelerator bearing

Extended Sentry Alarms

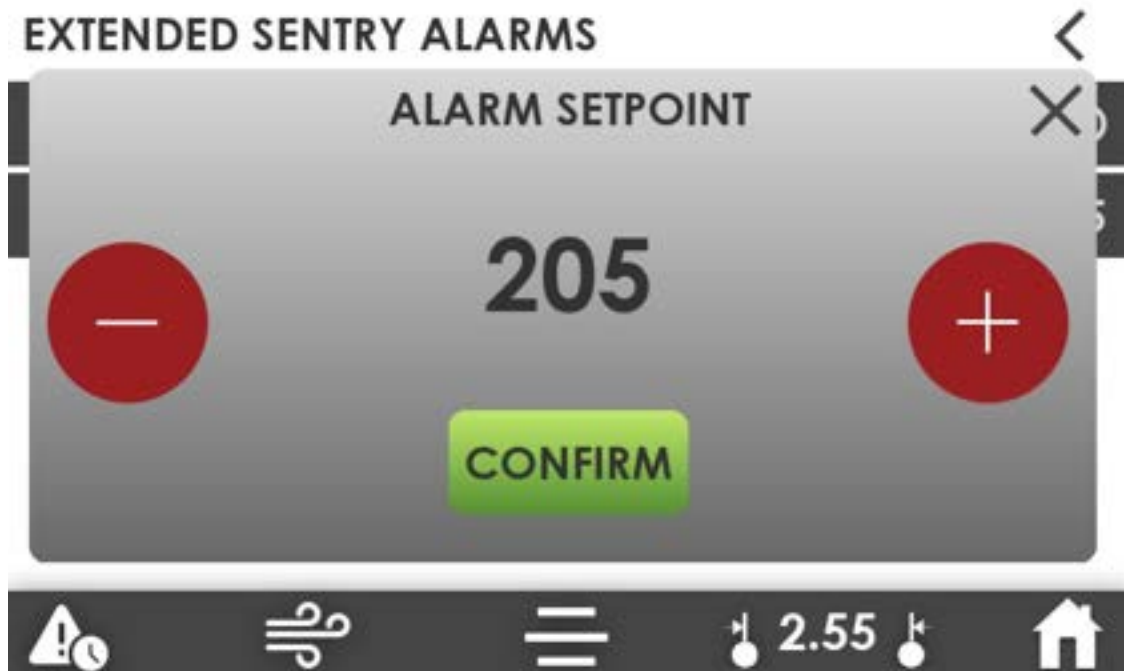

On the extended sentry alarms page a user has the ability to activate or deactivate the alarm for the extended sentry bearings. The extended sentry alarm set point will come set at 205 °F. The user has the ability to change the alarm set point . **SCHERER INC IS NOT RESPONSIBLE FOR AN ACCELERATOR OR CUTTER HEAD BEARING FAILURE.**

Bearing Alarms

Similar to the Sentry 2.0, the Sentry 4.0 has set alarms for the kernel processors bearings. Oil lubricated kernel processors have different set alarms than grease kernel processors. It is important to make sure your Sentry 4.0 system is set to the correct lubrication.

Oil Kernel Processor

Warning (Yellow) - 205

Alarm (Red) - 225

Grease Kernel Processor

Warning (Yellow) - 260

Alarm (Red) - 290

When the temperature threshold gets into the red an alarm will go off and a screen will appear giving the user the opportunity to suppress the alarm. The alarm suppression will only work for a few moments. If the bearing is continually ran in the severe temperature threshold, the alarm will continue to go off.



Bearing Alarm Times

Every time a bearing temperature goes into the set thresholds that time is recorded in the alarm times section. This feature can be accessed by selecting the alarm symbol in the bottom left corner on the main page.



Alarm Times	
Roll Front Left: 00:02:32 --:--:--	Cumulative Alarm Time 00:05:23 Alarm Suppression 5
Roll Front Right: --:--:-- --:--:--	
Roll Rear Left: --:--:-- 00:05:23	
Roll Rear Right: 00:02:32 --:--:--	
Cutter Left: --:--:-- --:--:--	
Cutter Right: --:--:-- --:--:--	
Blower Left: --:--:-- --:--:--	
Blower Right: --:--:-- --:--:--	
Idle Pulley: --:--:-- --:--:--	

2.55

Temperature Screen

An operator has the option of viewing all four kernel processor bearing temperatures and all four extended sentry temperatures on the same screen. To do so select the grey side bar on the main page . This selection will need to be selected three times. The first selection will bring up the extended sentry alarms, second will bring up idle pulley, and the third will bring up the 8 temperature page.

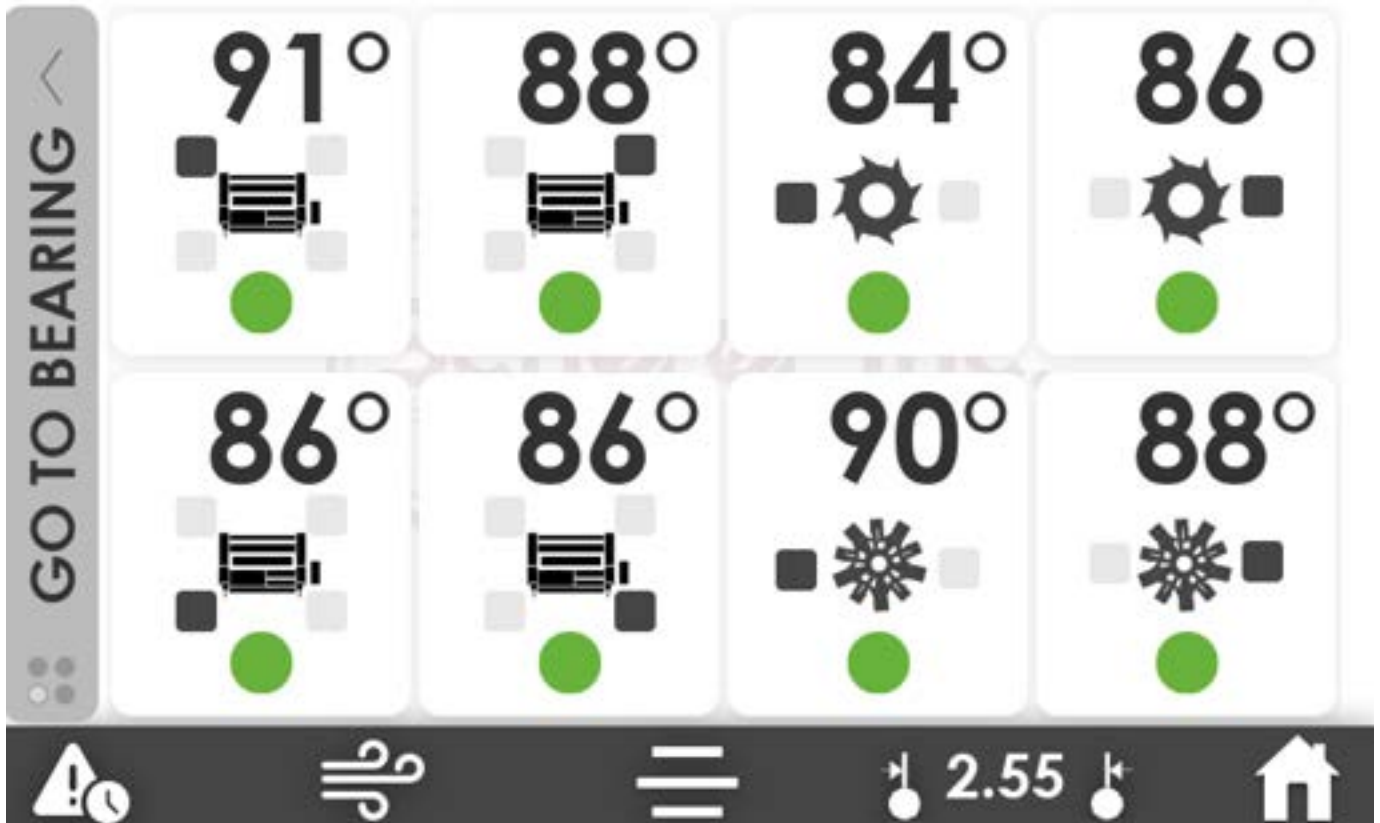

Scherer Sentry 4.0 - ASM10629



ITEM NO.	PART NUMBER	DESCRIPTION	QTY.
1	BLT10237	BUTTON HEAD SCREW	4
2	BLT10238	BOLT	4
3	NUT10069	NUT	4
4	PM1006	MOUNTING ARM	1
5	PM21004.1	MAGNET	4
6	PM22010	PLUG CAP ASSEMBLY	1
7	SPL10253	OVS50 DISPLAY	1
8	SPL10254	SENTRY 4.0 CONTROL MODULE	1
9	SPL10255	POWER CABLE	1
10	SPL10256	SENTRY 4.0 HARNESS	1
11	SPL10278	BALL MOUNT	1
12	SPL10288	BALL MOUNT C-CLAMP	1
13	SPL10312	HARNESS JUMPER	1
14	SPL10313	ON/OFF SWITCH	1
15	SPL10327	SPACER	4
16	SPL10340	KP CABLE	1
17	SPL10350	KP CABLE CAP	1
18	WSH10015	LOCK WASHER	4
19	WSH10052	FLAT WASHER	4
20	WSH10053	LOCK WASHER	4

BELT OPTIONS

Belt	Current Scherer Part #	Old Part #	Drive
6 Groove	SCHB10004	0090 256.1 HPD1335	Standard Drive
7 Groove	HPD1435-7	HPD1337-7 HPD1335-7	Standard Drive

Information necessary to determine which KP Belt customer needs:

- 1) Machine Serial # & year
- 2) KP Serial #
- 3) Which drive system equipped with:
 - a. Tension arm angle and location will determine which drive the machine has.
- 4) # of grooves on KP & machine drive pulleys.



Standard Drive System

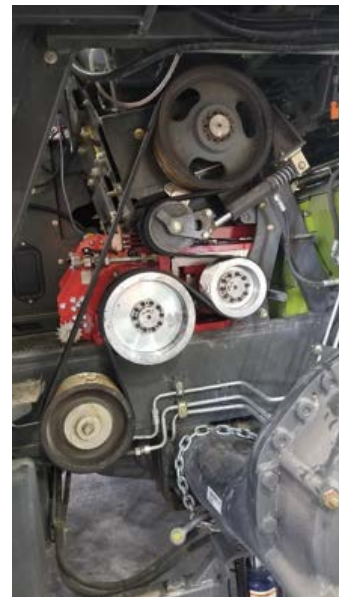

S Drive System

7 Groove Pulley Options

ASM10009—50% Differential

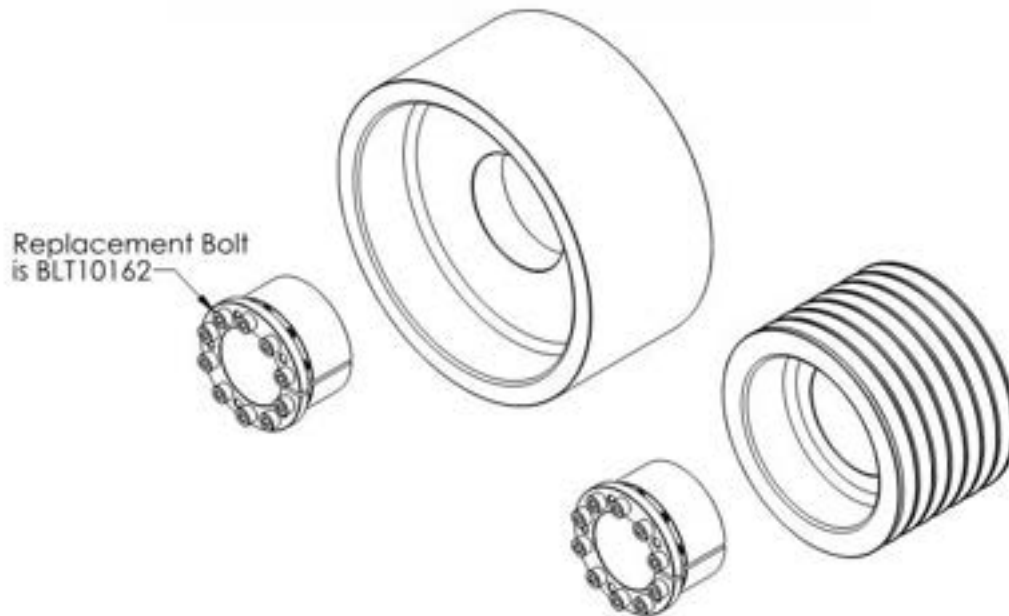

ITEM NO.	PART NUMBER	DESCRIPTION	QTY.
1	HOR1001	60MM TAPER ASSEMBLY	2
2	HOR1002-175	PULLEY 175mm	1
3	HOR1003-250	250mm SMOOTH PULLEY	1

ASM10107—30% Differential

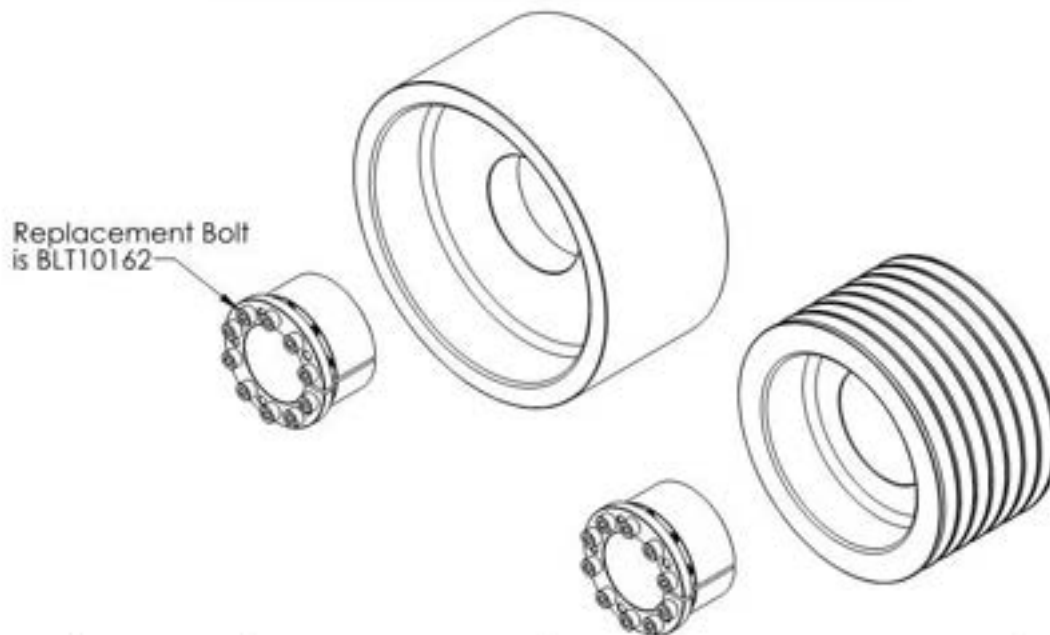

ITEM NO.	PART NUMBER	DESCRIPTION	QTY.
1	HOR1001	60MM TAPER ASSEMBLY	2
2	HOR1002-200	7 GROOVE PULLEY	1
3	HOR1003-250	250mm SMOOTH PULLEY	1

6 Groove Pulley Options

ASM10051—50% Differential

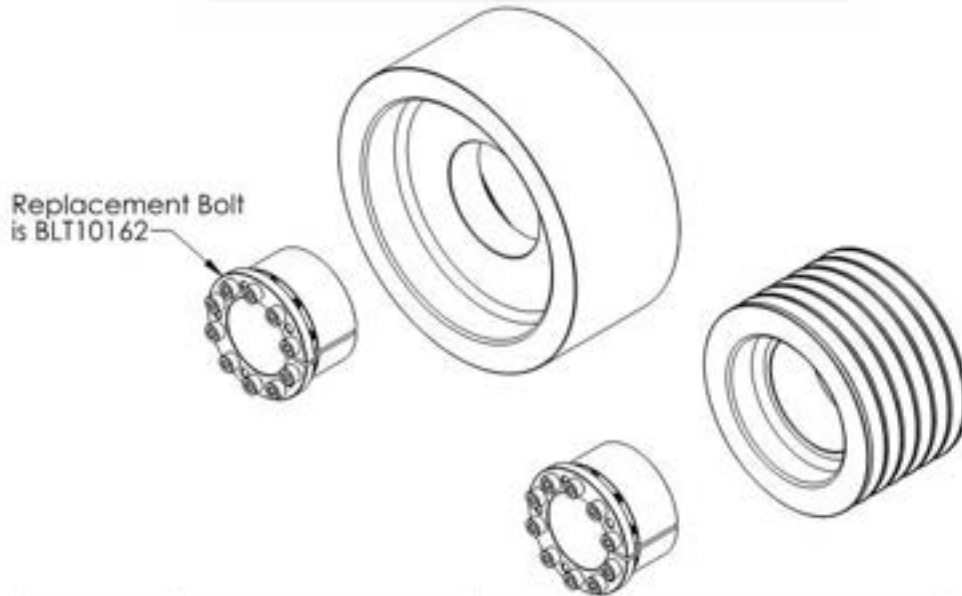

ITEM NO.	PART NUMBER	DESCRIPTION	QTY.
1	HOR1001	60MM TAPER ASSEMBLY	2
2	PRT10048	238mm 6GR SMOOTH PULLEY	1
3	PRT10049	165mm 6GR GROOVED PULLEY	1

ASM10160—30% Differential

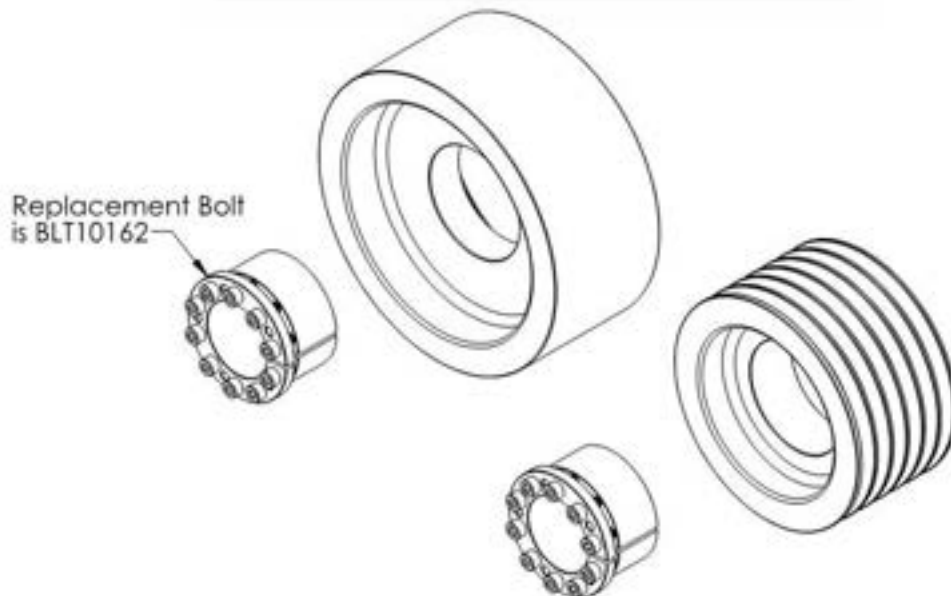

ITEM NO.	PART NUMBER	DESCRIPTION	QTY.
1	HOR1001	60MM TAPER ASSEMBLY	2
2	PRT10048	238mm 6GR SMOOTH PULLEY	1
3	PRT10050	184mm 6GR GROOVED PULLEY	1

Roll Gap Adjustment

Once the processor is installed in the cutter and some product has been run through it, you may need to adjust the roll gap. To do this, you will use the adjustment tool provided. Loosen the adjustment clamp lever on right side adjustment bolt. Rotate the bolt clockwise to open the gap, and counter-clockwise to close the gap. Return the adjustment tool to its original position. **The adjustment tool is also a lock for the roll position.** You will not be able to adjust the rolls closer than .5 mm (.02") because of the factory setting of the roll stops (prevents the rolls from hitting). **The processor is not intended to be run with the slide blocks against the roll stops.** When adjusting, watch pointer move across scale. Use the scale to determine your roll gap. The Processor was set at the factory to 2mm. When the adjustment is complete, make sure that the adjustment clamp lever is hand tightened. After you have a number of hours on your processor you may need to adjust your rolls together to compensate for wear. After a number of adjustments, and the pointer moves onto or near the red marks on scale, the adjustment bolts may become free from tension. If you still need to close your roll gap further you may have to clean behind the bearing slide plates and adjust roll stop bolts to allow for more movement.

Maintenance Intervals

1) After your Scherer Processor is installed

- Set your roll gap (See “Roll Gap Adjustment” section)
- Pass product through the machine, at least 5 loads under full power.
- Adjust rolls to your processing needs; however, **The Scherer Processor is not intended to be run against the roll stops so adjust accordingly.**
- Check adjustments 5 to 10 hours later to ensure adjustments are holding at your desired position. Check pulley alignment and make sure locking hubs are firmly in place.
- If equipped with air tension kit, check air tension on drive belt and set air pressure according to specific model.

7-groove drive: 90 to 95psi

2) 50 Hours

- Grease adjustment bolt zerks on processor (2 pumps)
- Visually inspect for damage to springs, bolts, shafts, pulleys, wiring, oil lines, etc.

3) 250 Hours

- Visually inspect for damage to springs, bolts, shafts, pulleys, wiring, oil lines, etc.
- Roll back processor and visually inspect rolls, roll gap, and the overall condition of the processor.
- If roll gap is wider at one end, there is also a possibility that the rolls just need to be adjusted.
- If equipped with Scherer idle components, grease lower idle pulley on drive system, and tension pulley (2 pumps each)

4) End of Season (VERY IMPORTANT)

- End of season maintenance will help reduce bearing failures and greatly reduce down time while harvesting.
- Use air to clean off the Processor.

- If you decide to power wash the processor, **immediately dry the processor and open it to expose bearing housings and rolls after power washing.** there is a good possibility that water penetrated the seals of the bearing and bearing damage would be imminent. After power washing the processor, you can prevent bearing damage by immediately servicing the processor and following the next few steps.
- Remove the tops of the bearing housings with a soft mallet and inspect the condition of the oil and bearing. Be very careful with the mating surfaces of the castings since they are machined surfaces and keep the top half with the bottom half since they are machined as a mating pair and are numbered accordingly.
- If there is no contamination, clean bearing housings and replace the felt seals (HPR1009). (See “End of Year Roll Maintenance” section)
- If contamination is present, the bearing casting needs to be removed and cleaned thoroughly. The oil line and the temp sender should be removed in order to clean the casting. New felt can then be installed. The bearing may also need to be replaced if there is a substantial amount of contamination in the bearing casting. An inspection of the bearing rollers may also help determine if the bearing needs to be replaced.
- Make sure all bearings get fresh Scherer KP oil after they have been inspected or changed. See section “End of Year Roll Maintenance”.
- Inspect spool seal for wear.
- Rolls should be covered with a rust inhibitor to prevent corrosion. Corrosion on rolls may cause rolls to be out of tolerance, leading to vibration.

Coalescing Filter / Schermist®

Inspect and/or replace filter element (HPT1411.1) after each season. (See Part Number HPT1411 Parts List section).

Replace Schermist® head gaskets every season (OM1026 — See Part Schermist® Head Rebuild section).

Recommended End of Year Parts Replacements

HPD1411.1	1X	Coalescing Filter & O-ring Kit
HPR1009	12X	Bearing Felt Seals
OM1026	1X	Schermist® Gasket Kit
ASM10317	1X	Cheek Plate Replacement Kit
HPTB1075	1X	Bulb Seal Replacement Kit

Roll Change Instructions

1. Remove processor from the forage harvester. An air wand will also help keep things clean and free from debris.
2. Take a measurement from the frame to the pulley on the roll to be replaced so you know where to place the pulley on the new roll since the pulley alignment is critical.
3. Clean the bolt heads of the locking hub and remove the pulley from the roll that needs to be replaced.
4. Open KP as per instructions on page 51.
5. Disconnect and remove the temp sensors and the oil line fittings from the bearing housings of the roll to be replaced.
6. Remove bearing housing bolts (BLT10052)
7. Install new roll using bearing housing shear bolts (BLT10015 apply anti-seize) torque - 12 ft-lbs. (16 Nm) to align the bearing housings. The drive side bearing housing will be locked in place, so align the drive side bearing first. The idle side bearing will slide within the bearing housings so the idle side bearing housing will be able to be slid into place and align with the bolt holes after the drive side is in place.
8. Install the bearing housing bolts (BLT10052 apply anti-seize) torque - 160 ft-lbs. (217 Nm).
9. Close the processor. Reverse steps from page 51. Watch oil lines and wires so they don't get pinched between the two KP halves of the frame.
10. Install and tighten the top hinge bolts (BLT10109) apply anti-seize and torque to 111 ft-lbs/150 Nm. Torque the bottom hinge bolt (BLT10016) to 121 ft-lbs/164 Nm. Install the nuts onto the eye-bolt of the latch blocks (NUT10001) torque 93 ft-lbs. (126 Nm). Snug all hardware before torquing each individual component.
11. Install oil fittings and oil lines as well as temp sensors.

Processor Opening Process

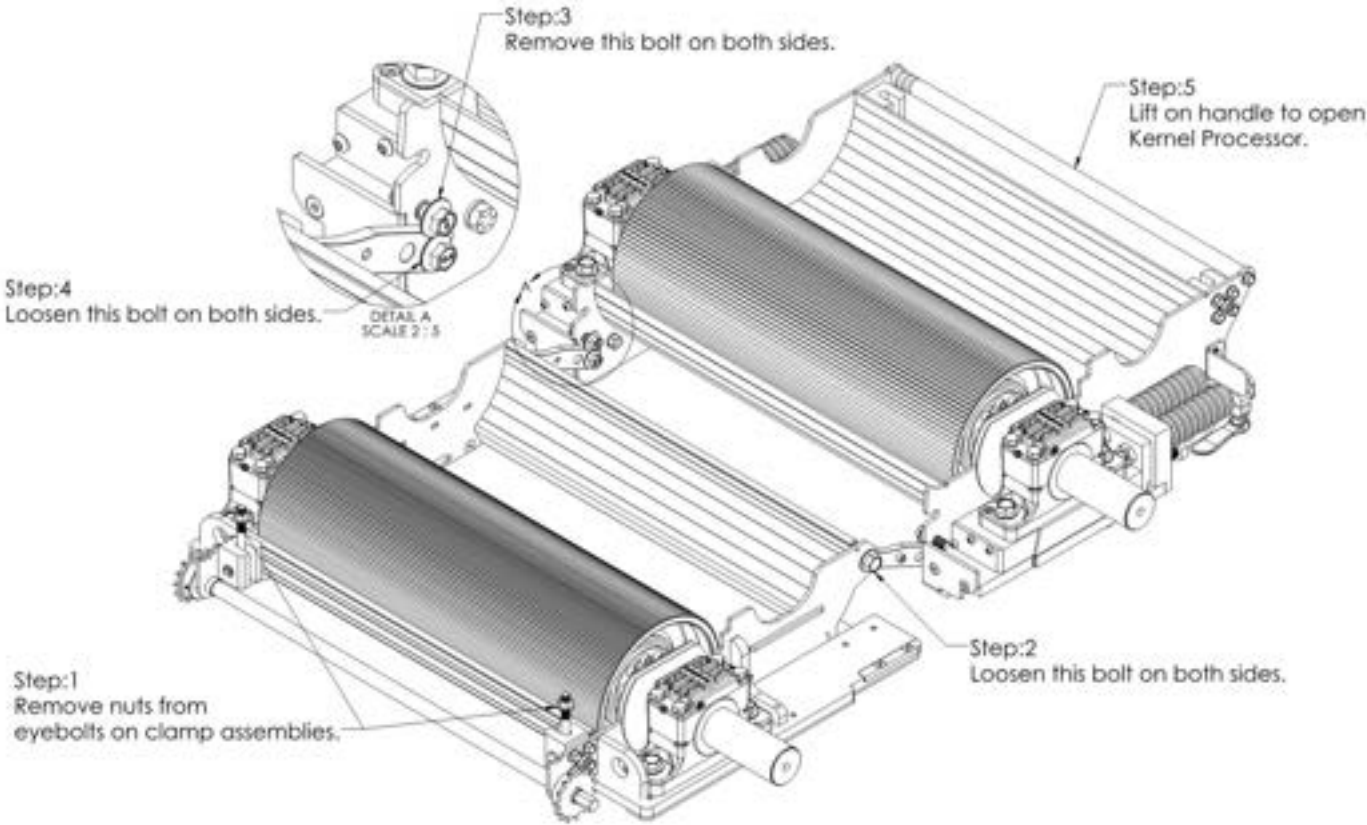
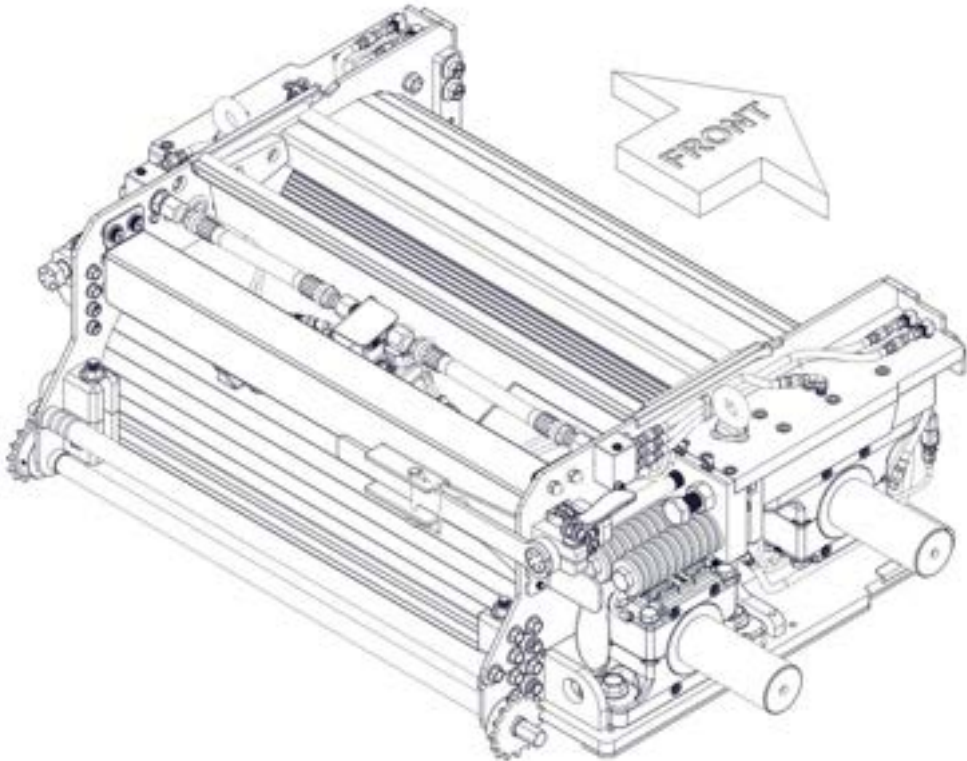

End of Year Roll Maintenance

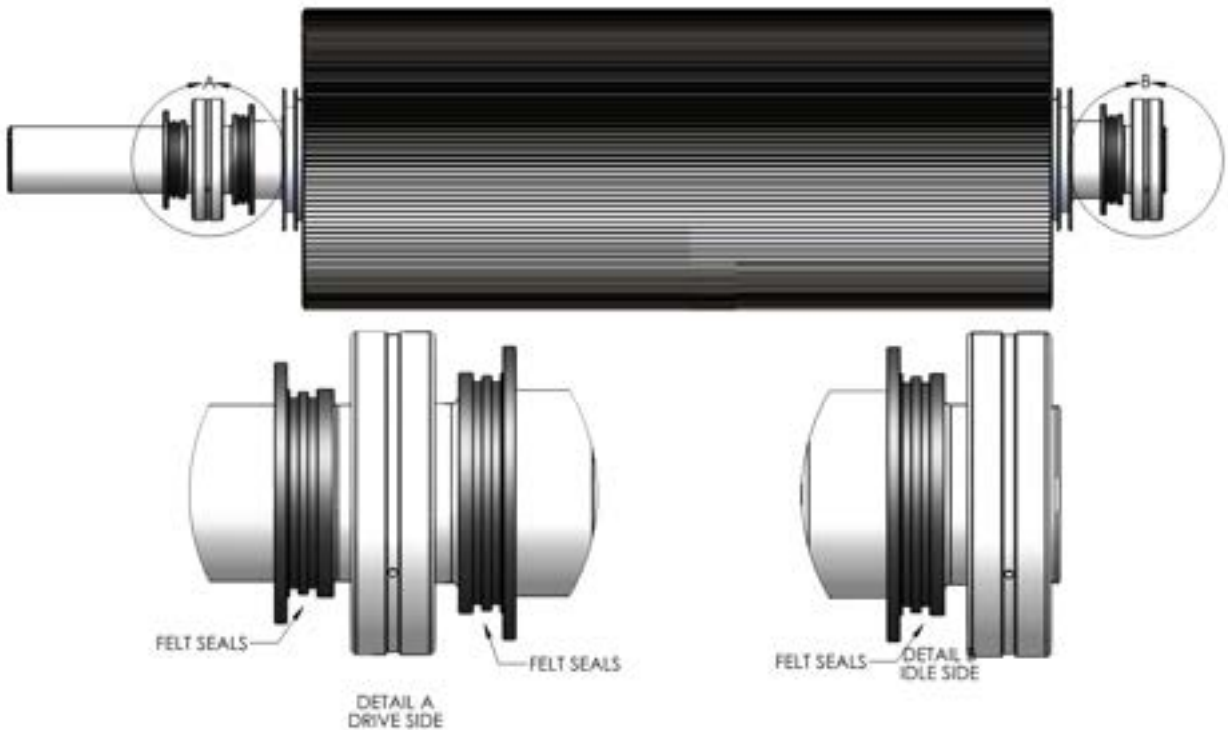

- At the end of the season it is highly recommended that KP roll housings are disassembled and inspected for debris and unusual wear.
- Located on the brass seals there are 6 felt seals (HPR1009). At the end of the season these need to be removed and replaced. **IF SERVICING A GREASE KP ROLL THERE WILL BE NO FELT SEALS. GREASE KP'S DO NOT USE FELT SEALS. THIS IS DONE TO ALLOW THE GREASE TO PURGE DURING OPERATION.**

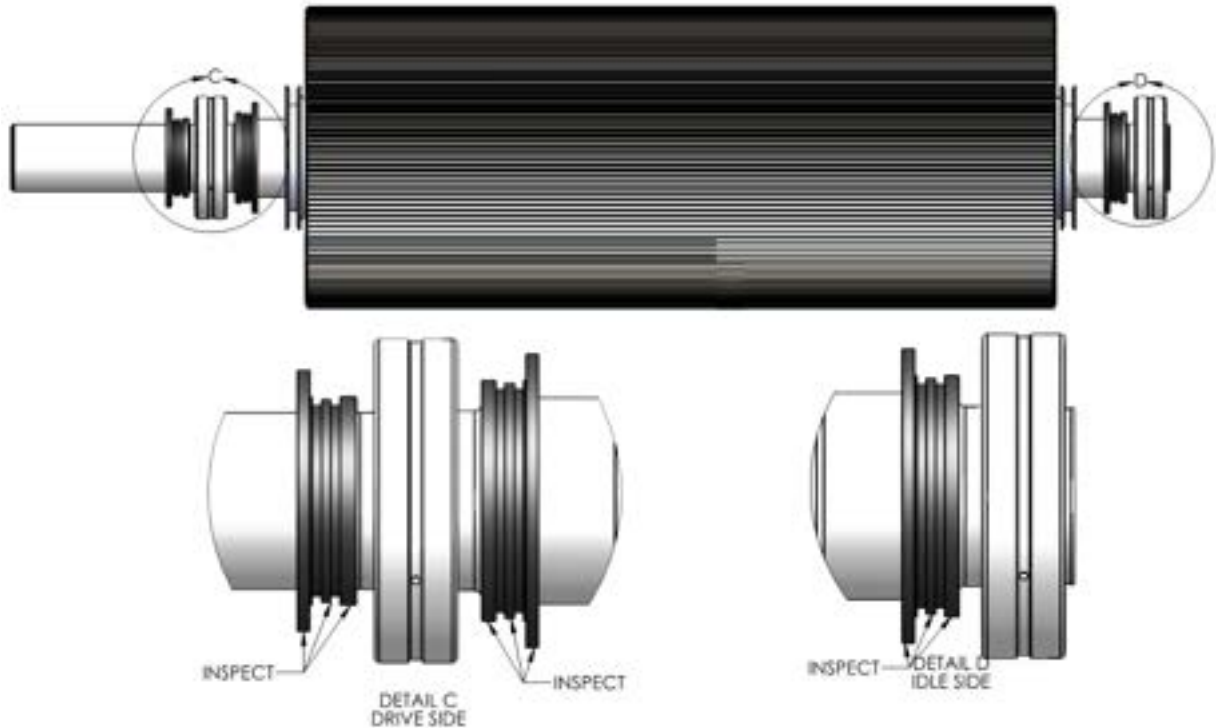

- With the felt seals removed inspect the brass seal surfaces for excessive wear or galling. If either excessive wear or galling is found, replace the components.
- The edges of the housings where the brass seals sit need to be inspected for wear and galling as well.
- With ISO 32 oil flush out the bearing housing cavity and the two roll bearings.
- After removal of the felt seals and inspection of the components the roll assembly can be rebuilt.
- Prior to installing the new felt seals soak them in ISO 32 oil.
- The new felt seals can be pressed into place with a flat screw driver. The green face of the felt will be facing out so that it contacts the brass seal. The ends of the felt can be trimmed with a utility knife so that the felt is flush with the edge of the housing.
- The housings can be reassembled and filled with 14.75 CC's of Scherer KP oil. This is equivalent to ISO 32 oil.
- Apply a thin coat of oil or some type of rust inhibitor to the roll corrugation to avoid corrosion.

Roll Life Measurement

When servicing rolls at the end the season, roll profile gauges can be used to determine if the rolls have been worn out. When using the roll tooth gauges if the flat of the tooth is below the engraved line then the roll is past its recommend life.

The following roll gauge part numbers can be purchased for the \$975.

PRT10410 - 110 Tooth

PRT10411 - 145 Tooth

PRT10412 - 165 Tooth

New Roll



Used Roll



Worn Out Roll



Roll Bearing Removal and Installation

1. To remove the roll bearing, the housing must be disassembled. Remove the 4 bolts on top of the housings. Tap on the feet of the lower housing with a soft mallet to separate the two halves.

***NOTE*: Housings are machined as matched sets. The two halves are engraved to show parity.**



2. Remove the outer brass seal and then use the bearing removal tool (A0022) to remove the bearing.

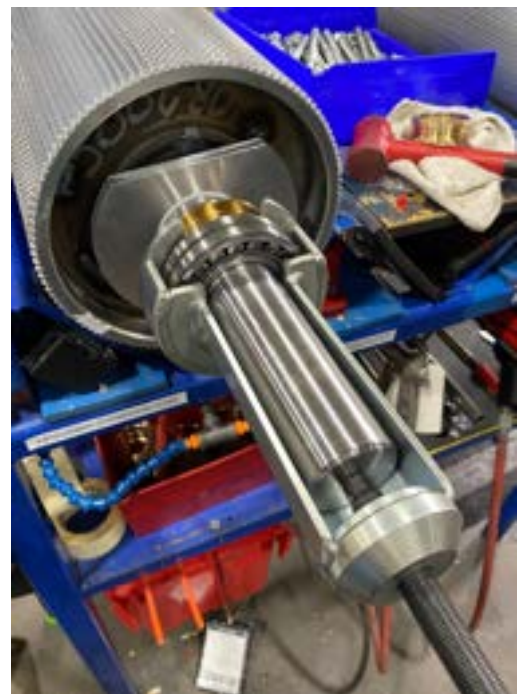

2. Remove inner brass housing seal and aluminum spool seal. Clean and inspect. Replace if any components show improper wear. Make sure to install the brass housing seal dry. **NO LUBRICANT**



3. Using the bearing heater (A0021) heat the bearing to 230 degrees F (110 degrees C). Using proper PPE (Personal Protective Equipment) take the bearing and slide it onto the shaft until it hits the machined step. If the bearing gets jammed, pull the bearing off again with the removal tool (A0022) and re-heat the bearing and install again. Reassemble the bearing housing and torque the housings bolts to 65 Ft-lbs (88Nm).



Schermist® Head Rebuild

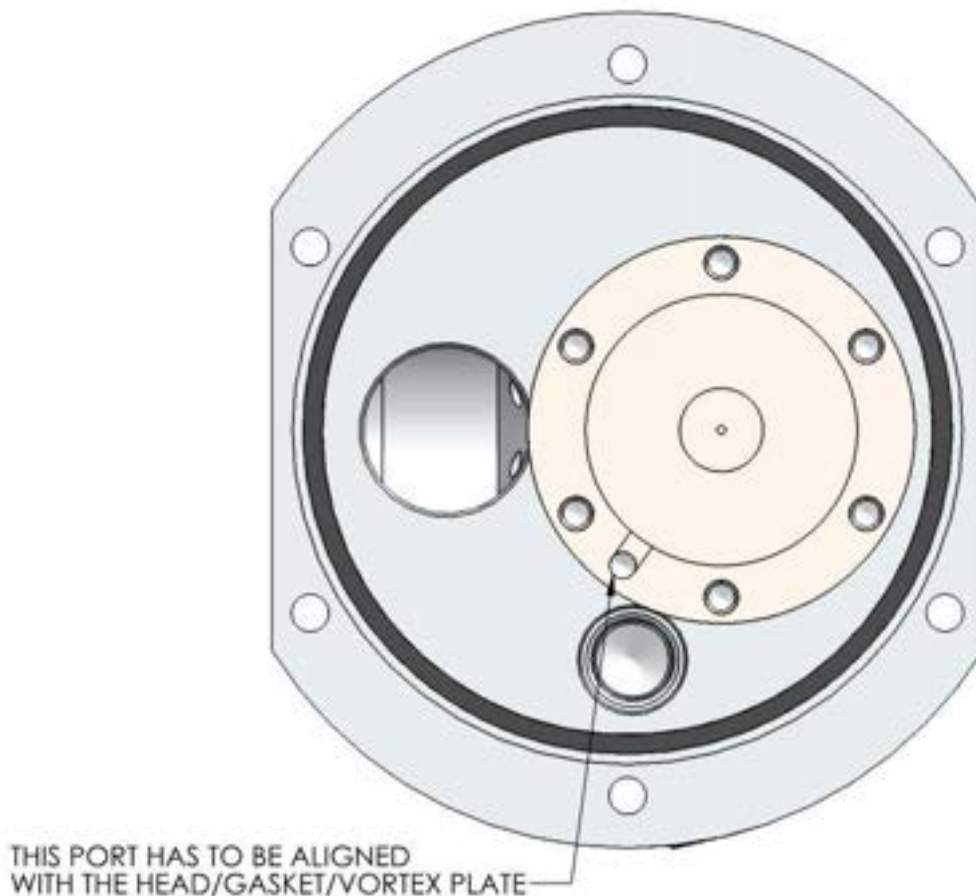

Cleaning Instruction:

1. After the oil tank head assembly has been removed from the oil tank reservoir, disassemble the parts as shown.
2. Clean all parts in a safe, clean solvent. Air dry after cleaning.
3. **CRITICAL ASSEMBLY FEATURE** Reassemble the parts as shown above. The oil port hole must align through all 3 components: Head / Venturi Gasket / Vortex Plate.
4. Reassemble head and torque the 6 screws to 3 Ft-lbs.
5. Install head gasket when installing the Schermist® head onto the oil reservoir.
6. If head is disassembled then venturi and head gasket have to be replaced. This kit can be purchased as OM1026

Important Torque Specifications

Part	Torque Ft-lbs	Torque Nm	Apply
BLT10015 (Bearing Housing Shear Bolt)	12	16	Anti-Seize
BLT10052 (Bearing Housing Mounting Bolt)	160	217	Anti-Seize
BLT10016 (Bottom Hinge Bolt)	121	164	Anti-Seize
KMP10047 (Middle Hinge Bolt)	60	81	Anti-Seize
BLT10109 (Top Hinge Bolt)	111	150	Anti-Seize
JDBM1108 (Slide Stop Bolt)	N/A	N/A	Anti-Seize
HOT1037 (Adjustment Bolt)	N/A	N/A	Anti-Seize
D1326 (Spring Rod Bolt)	173	235	Anti-Seize
BLT10008 (Latch Block Mounting Hex Bolt)	28	38	Loctite 242
BLT10009 (Latch Block Mounting SHCS Bolt)	47	64	Loctite 242
BLT10008 (Lifting Handle Bolt)	28	38	Loctite 271
BLT10107 (Slide Bearing Cap Bolt)	24	33	Loctite 271
BLT10110 (Slide Bearing Cap Bolt)	47	64	Loctite 271
IDTM1003 (Spring Rod)	330	447	Loctite 271
BLT10000 (Bearing Housing Bolt)	65	88	N/A
BLT10071 (Baffle Cup Bolt)	3	4	N/A
BLT10140 (Schermist Head Bolt)	3	4	N/A
BLT10046 (Inner Slide Mounting Bolt)	62	84	N/A
NUT10001 (Latch Block Nut)	108	146	N/A

Apply Anti-Seize
Apply Blue Loctite 242
Apply Red Loctite 271
No Application

Top Frame

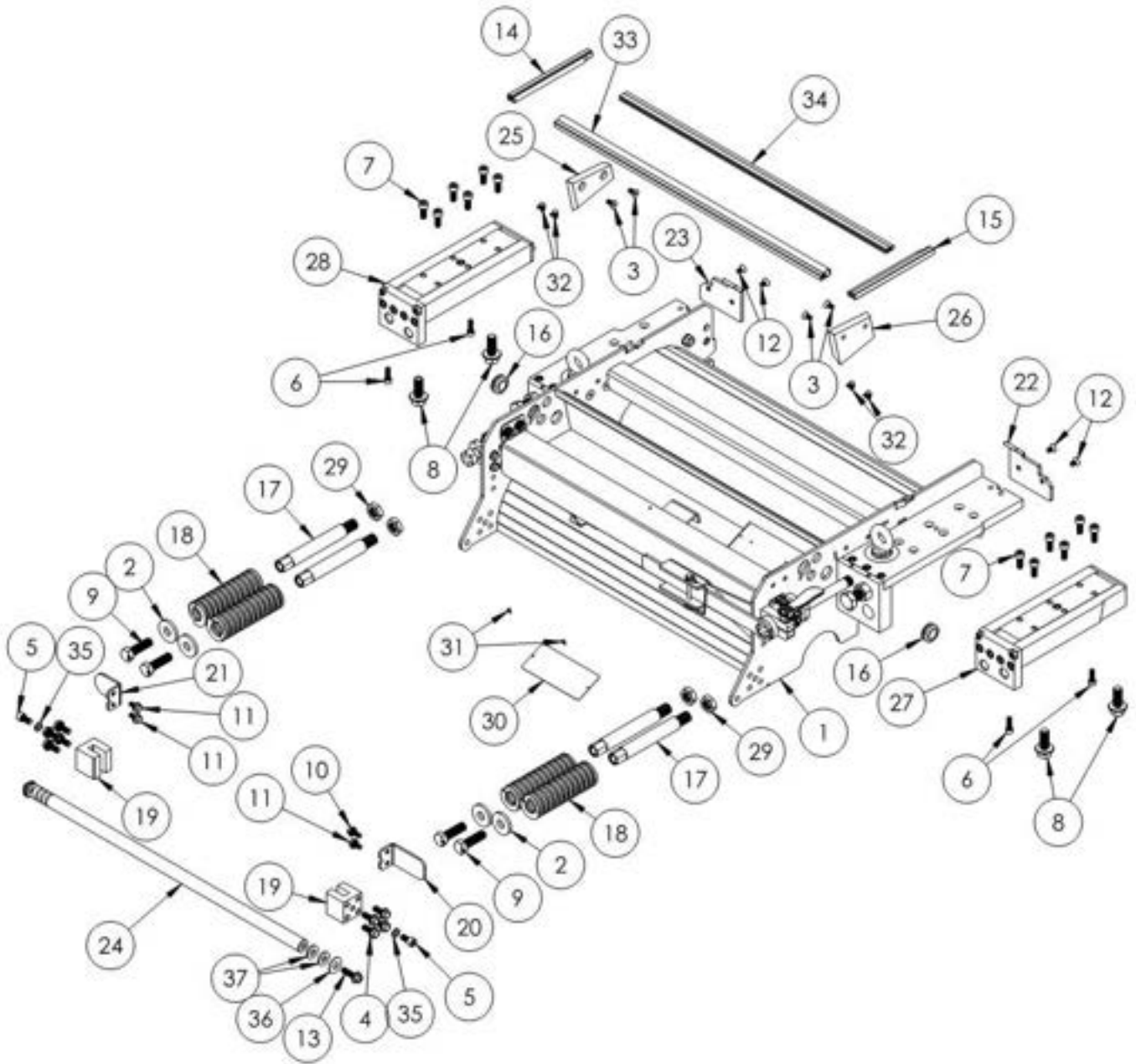

Top Frame Parts List

ITEM NO.	PART NUMBER	DESCRIPTION	QTY.
1	ASM10079	S980 & S975 TOP FRAME ASSY	1
2	B1002	SPRING BOLT WASHER	4
3	BLT10005	FLAT HEAD SCREW	4
4	BLT10008	SERRATED FLANGE BOLT	8
5	BLT10009	SOCKET HEAD CAP SCREW	2
6	BLT10015	SOCKET HEAD CAP SCREW	4
7	BLT10046	SOCKET HEAD CAP SCREW	12
8	BLT10052	FLANGE BOLT	4
9	BLT10103	HEX HEAD BOLT	4
10	BLT10104	SERRATED FLANGE BOLT	1
11	BLT10105	SERRATED FLANGE BOLT	3
12	BLT10110	FLAT HEAD SCREW	4
13	BLT10251	FLANGE BOLT	2
14	HPT1010L	LEFT SHROUD SEAL	1
15	HPT1010R	RIGHT SHROUD SEAL	1
16	HPT1106	GROMMET	2
17	JDTM1003	SPRING ROD METRIC	4
18	JDTM1039	BEARING SLIDE SPRING	4
19	JDTM1057	TOP LATCH BLOCK	2
20	KMP10030	RIGHT SPRING GUARD	1
21	KMP10031	LEFT SPRING GUARD	1
22	KMP10034	DRIVE SIDE ROLL OVER BRACKET	1
23	KMP10035	IDLE SIDE ROLL OVER BRACKET	1
24	KMP10036	LIFT HANDLE	1
25	KMP10041	IDLE SIDE CHEEK PLATE	1
26	KMP10042	DRIVE SIDE CHEEK PLATE	1
27	KMP20011	DRIVE SIDE SLIDE ASSEMBLY	1
28	KMP20013	IDLE SIDE SLIDE ASSEMBLY	1
29	NUT10033	HEX JAM NUT	4
30	PRT10085	SCHERER SERIAL PLATE	1
31	SPL10047	DRIVE SCREW	2
32	SPL10060	GREASE ZERK	4
33	T1054	5/8" 90 DEG BULB SEAL	1
34	TB1043	SHROUD SEAL	1
35	WSH10001	LOCK WASHER	2
36	WSH10007	FLAT WASHER	2
37	WSH10008	RUBBER WASHER	4

Top Frame Adjustment Parts

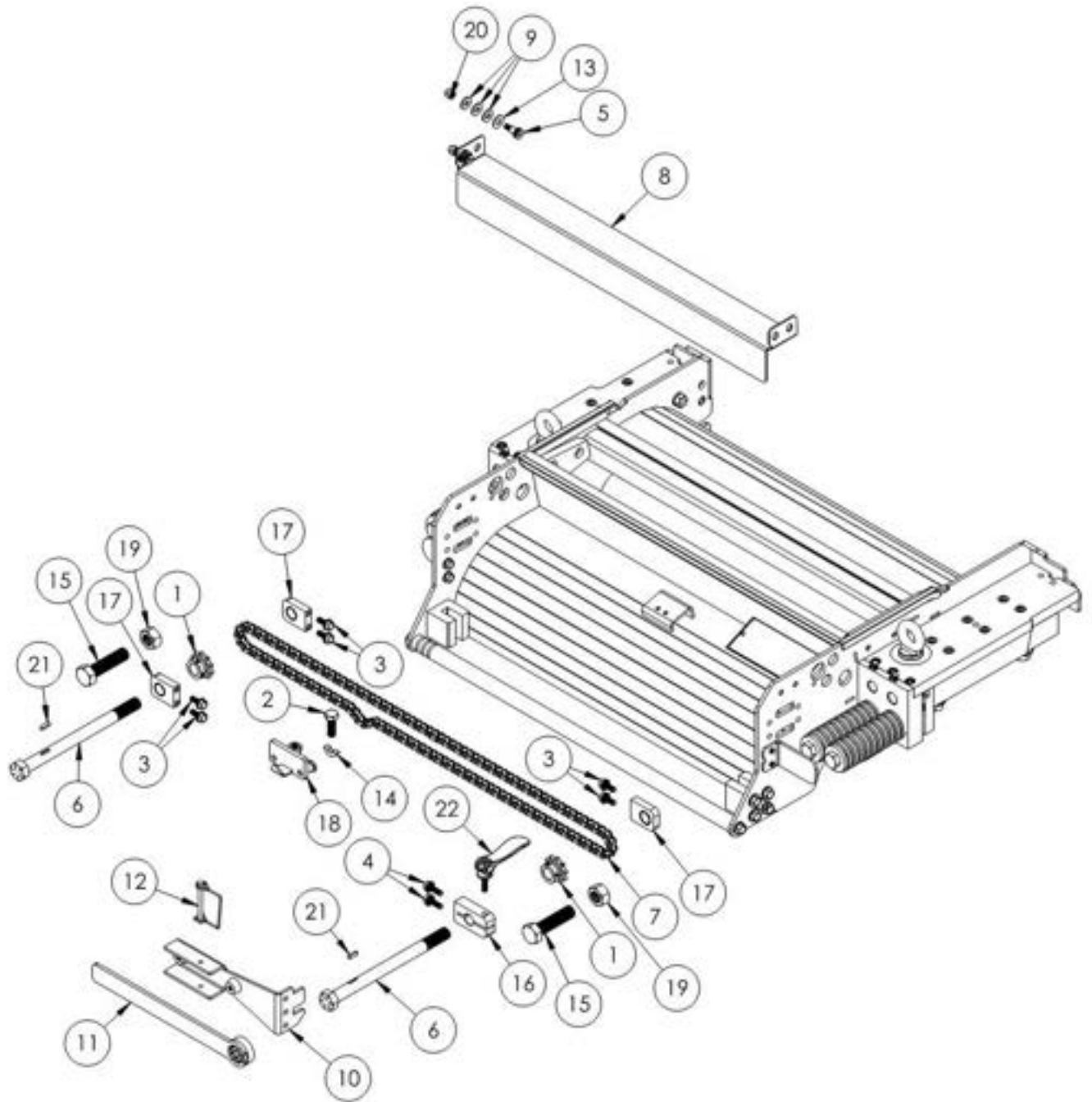

Top Frame Adjustment Parts List

ITEM NO.	PART NUMBER	DESCRIPTION	QTY.
1	B1067	CHAIN ADJUSTMENT SPROCKET	2
2	BLT10028	HEX HEAD BOLT	1
3	BLT10104	SERRATED FLANGE BOLT	6
4	BLT10106	SERRATED FLANGE BOLT	2
5	BLT10111	SHOULDER BOLT	2
6	HPST1037	ADJUSTMENT BOLT	2
7	HPT1048	ADJUSTMENT CHAIN	1
8	HPT1055	HP CHAIN GUARD	1
9	HPT1069	RUBBER WASHER	6
10	HPT1097	ADJUSTABLE WRENCH MOUNT ASSEMBLY	1
11	HPT1098	ADJUSTMENT WRENCH	1
12	HPT1099	LOCKING PIN	1
13	HPT1115	SS WASHER	2
14	JDBM1060	WOODRUFF KEY	1
15	JDBM1108	SLIDE STOP BOLT	2
16	KMP10046	RIGHT ADJ BLOCK LOCK PLATE	1
17	KMP20004	METRIC ADJ BOLT GUIDE ASSY	3
18	KMP20007	CHAIN TENSION BRACKET	1
19	NUT10000	HEX NUT	2
20	NUT10029	ACORN NUT	2
21	SPL10003	MACHINE KEY	2
22	SPL10061	ADJ BOLT CLAMP HANDLE	1

Bottom Frame

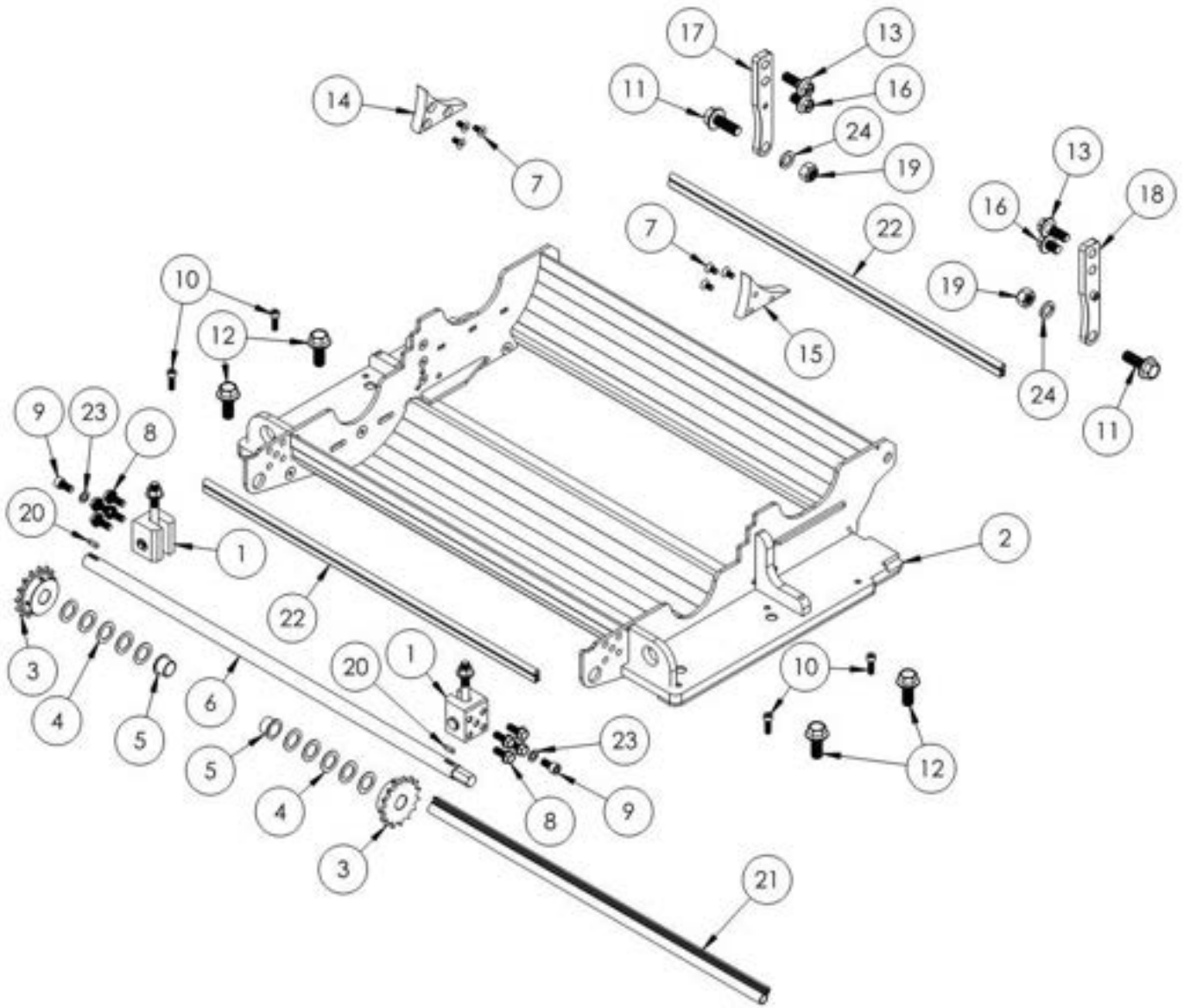

Bottom Frame Parts List

ITEM NO.	PART NUMBER	DESCRIPTION	QTY.
1	ASM10049	LATCH BLOCK BOTTOM ASSEMBLY	2
2	ASM10082	S975 BOT FRAME ASSY	1
3	B1027-15	POSITION ROD SPKT (498/497)	2
4	B1029	FLAT WASHER	10
5	B1030	POSITION ROD BUSHING	2
6	B1039	PROCESSOR POSITION ROD	1
7	BLT10005	FLAT HEAD SCREW	6
8	BLT10008	SERRATED FLANGE BOLT	8
9	BLT10009	SOCKET HEAD CAP SCREW	2
10	BLT10015	SOCKET HEAD CAP SCREW	4
11	BLT10016	FLANGE BOLT	2
12	BLT10052	FLANGE BOLT	4
13	BLT10109	FLANGE BOLT	2
14	KMP10043	IDLE SIDE BOTTOM CHEEK PLATE	1
15	KMP10044	DRIVE SIDE BOTTOM CHEEK PLATE	1
16	KMP10047	HINGE FLANGE BOLT	2
17	KMP20005	METRIC LEFT HAND HINGE	1
18	KMP20006	METRIC RIGHT HAND HINGE	1
19	NUT10002	LOCK NUT	2
20	SPL10003	MACHINE KEY	2
21	T1054	5/8" 90 DEG BULB SEAL	1
22	TB1043	SHROUD SEAL	2
23	WSH10001	LOCK WASHER	2
24	WSH10003	LOCK WASHER	2

ASM10049 - Latch Block

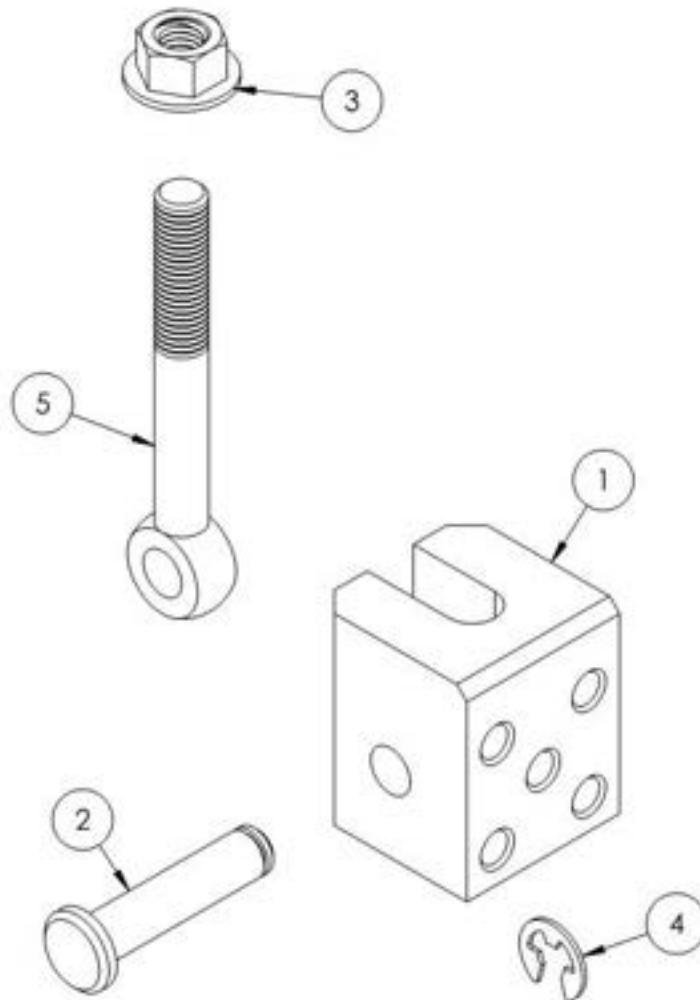

ITEM NO.	PART NUMBER	DESCRIPTION	QTY.
1	JDBM1035	CLAMP BRACKET	1
2	JDBM1133	METRIC LATCH BLOCK EYE-BOLT PIN	1
3	NUT10001	SARRATED FLANGE NUT	1
4	SPL10005	E-CLIP	1
5	SPL10009	EYE BOLT	1

KMP20011 - Drive Slide

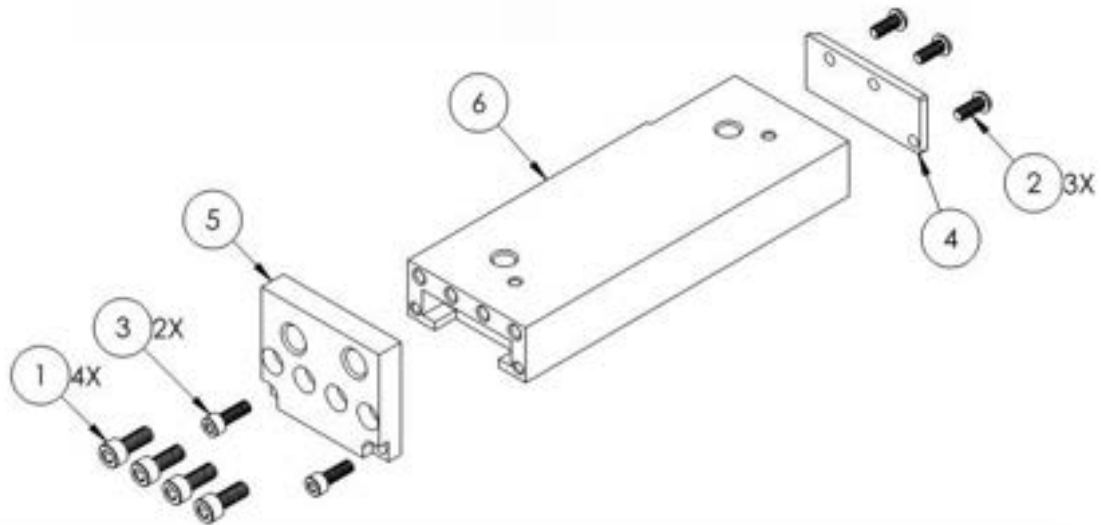

ITEM NO.	PART NUMBER	DESCRIPTION	QTY.
1	BLT10010	SOCKET HEAD CAP SCREW	4
2	BLT10024	BUTTON HEAD BOLT	3
3	BLT10107	SOCKET HEAD CAP SCREW	2
4	HPT1017	RIGHT SLIDE FRONT CAP	1
5	KMP10040	DRIVE SIDE BRG CAP	1
6	KMP20012	DRIVE SIDE OUTER & INNER ASSY	1

KMP20013 - Idle Slide

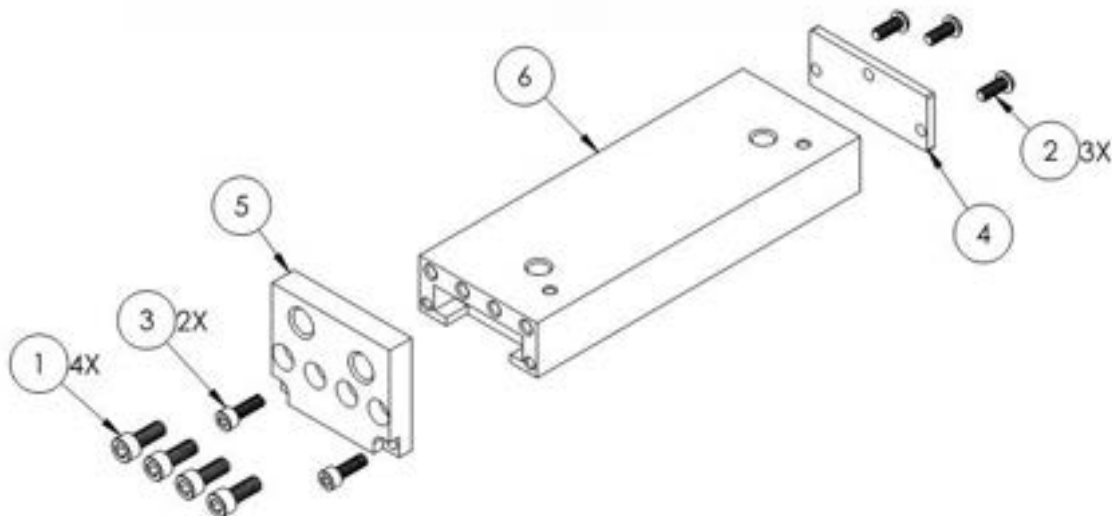

ITEM NO.	PART NUMBER	DESCRIPTION	QTY.
1	BLT10010	SOCKET HEAD CAP SCREW	4
2	BLT10024	BUTTON HEAD BOLT	3
3	BLT10107	SOCKET HEAD CAP SCREW	2
4	HPT1002	LEFT SLIDE FRONT CAP	1
5	KMP10039	IDLE SIDE BRG CAP	1
6	KMP20014	IDLE SIDE OUTER & INNER ASSY	1

Temperature Wiring Harness

ASM10445

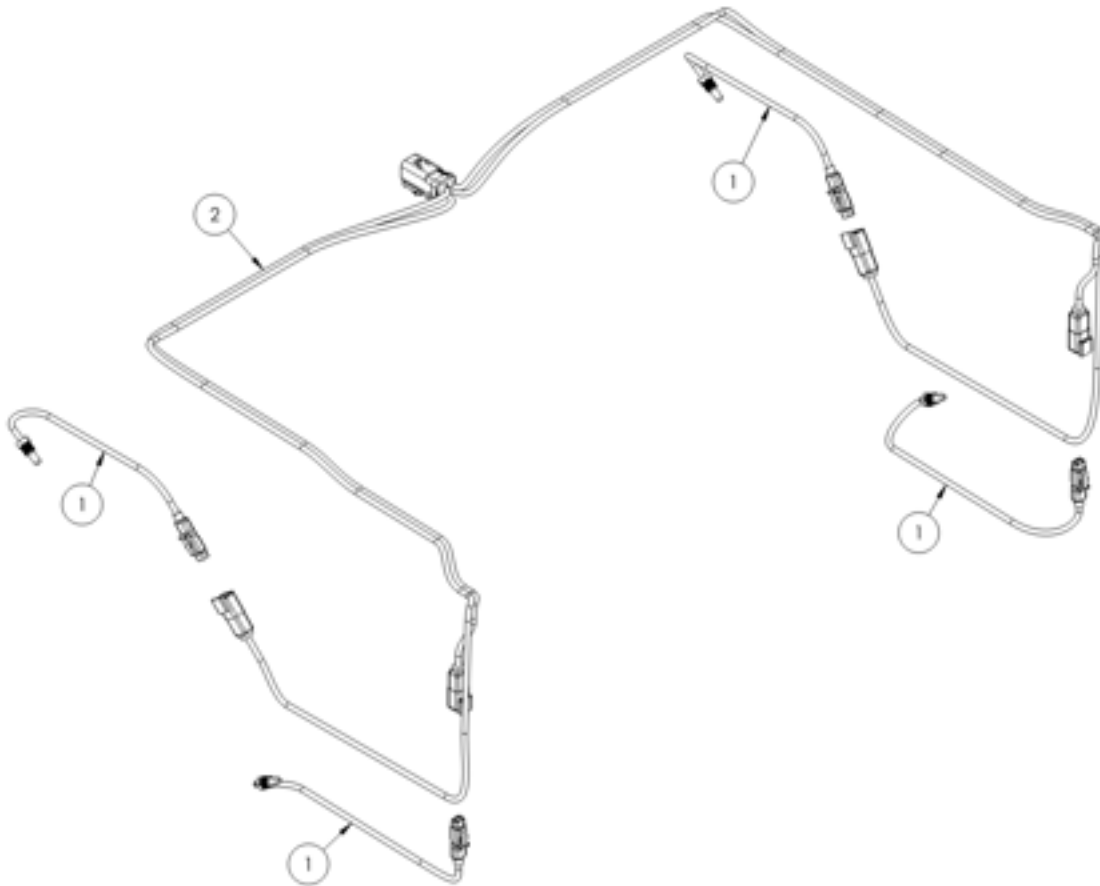
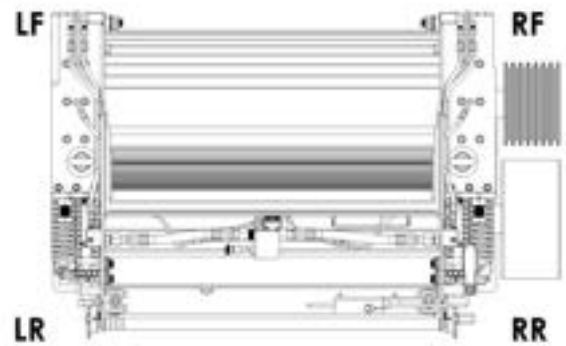

ITEM NO.	PART NUMBER	DESCRIPTION	QTY.
1	PM22007	TEMPERATURE PROBE	4
2	SPL10263	SPLITTER CABLE	1

Air Lubrication Lines

OM2029

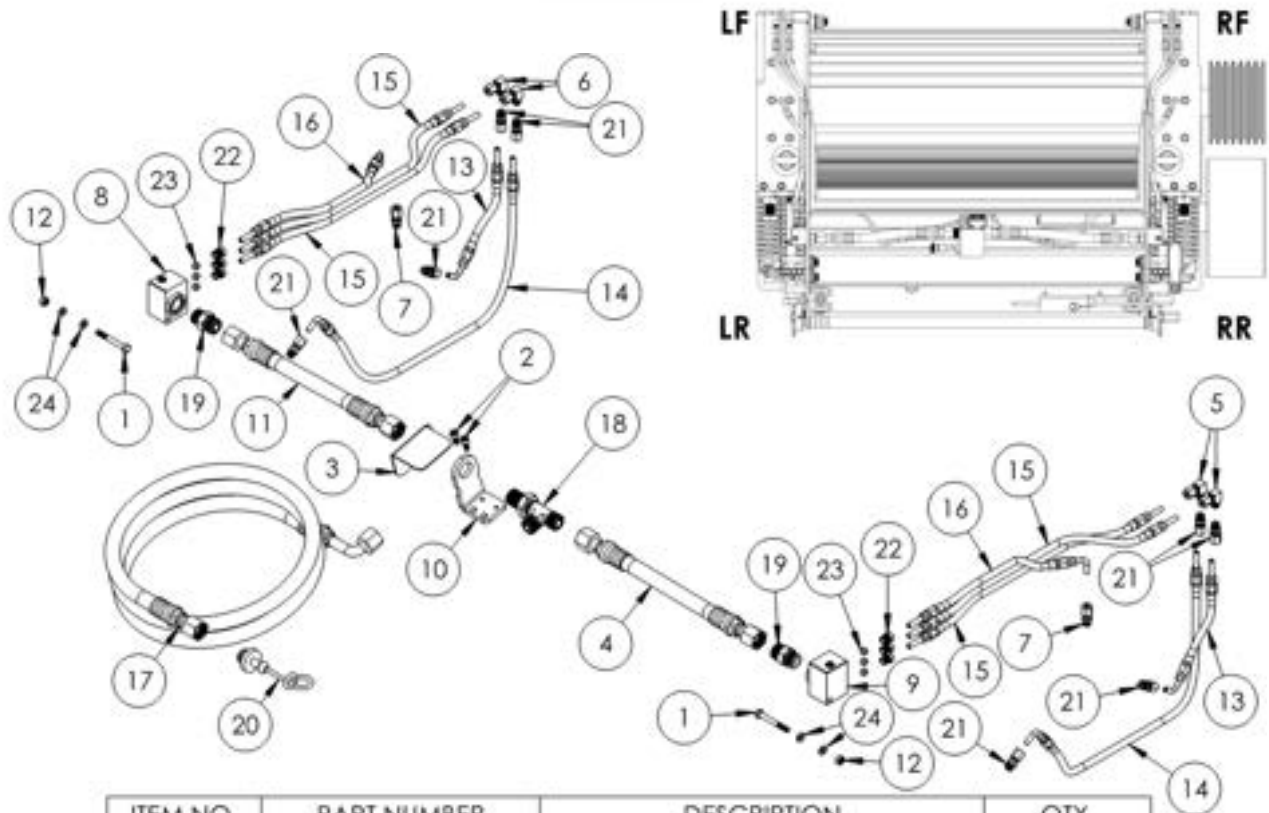

ITEM NO.	PART NUMBER	DESCRIPTION	QTY.
1	BLT10020	HEX HEAD BOLT	2
2	BLT10113	SOCKET HEAD CAP SCREW	2
3	HPT1087	STAINLESS BULKHEAD GUARD	1
4	JDHM1152	TOP HYD HOSE	1
5	JDHM2000	DRIVE SIDE CONDENSOR FITTING	2
6	JDHM2001	IDLE SIDE CONDENSOR FITTING	2
7	JDHM2002	SLIDE CONDENSOR FITTING	2
8	JDTM2043	RH HYD MANIFOLD ASSY	1
9	JDTM2044	LH HYD MANIFOLD ASSY	1
10	KMP10055	MIST HOSE MOUNT	1
11	NBH1000	TOP HYD HOSE	1
12	NUT10003	LOCK NUT	2
13	OM1115	LUBRICATION LINE	2
14	OM1116	LUBRICATION HOSE	2
15	OM1117	LUBRICATION LINE	4
16	OM1118	LUBRICATION LINE	2
17	OM2033	HOSE OIL MISTER TO PROCESSOR	1
18	SPL10011	TEE FITTING	1
19	SPL10012	STRAIGHT ADAPTER	2
20	SPL10028	MALE CAP	1
21	SPL10076	BEKA-MAX STRAIGHT COUPLING	8
22	SPL10113	BEKA-MAX HOSE NUT	6
23	SPL10114	BEKA-MAX HOSE DBL CONE SLEEVE	6
24	WSH10004	FLAT WASHER	4

Grease/Oil Lubrication Lines

G2002

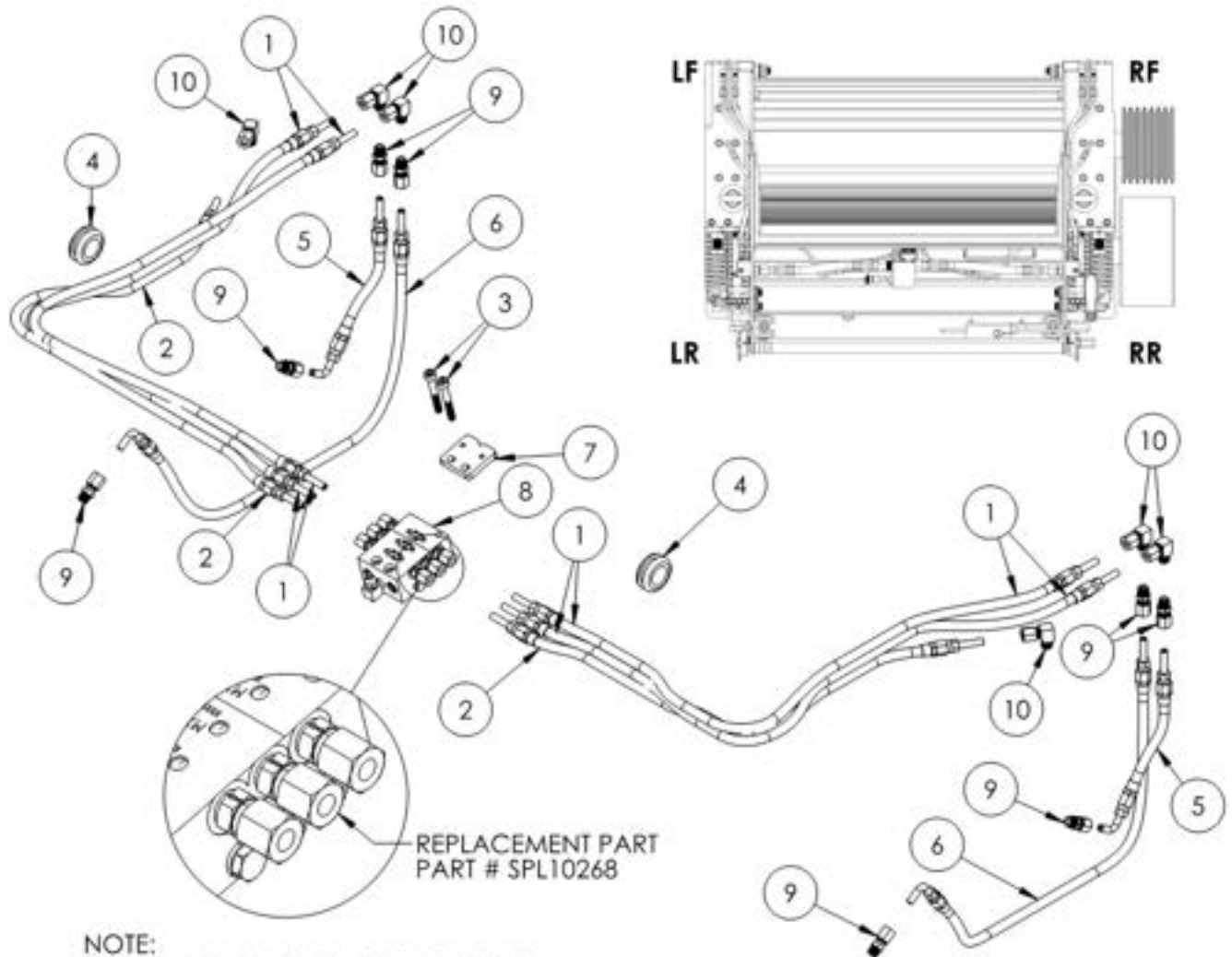

NOTE:
LUBRICATION LINE #1 - REAR BEARING
LUBRICATION LINE #1 - FRONT BEARING
LUBRICATION LINE #2 - SLIDE

ITEM NO.	PART NUMBER	DESCRIPTION	QTY.
1	ASM10083	LUBRICATION LINE	4
2	ASM10084	LUBRICATION LINE	2
3	BLT10141	SOCKET HEAD BOLT	2
4	HPT1106	GROMMET	2
5	OM1115	LUBRICATION LINE	2
6	OM1116	LUBRICATION HOSE	2
7	PM3040	MANUAL LUBE SENSOR MOUNT	1
8	SPL10073	DISTRIBUTION MANIFOLD	1
9	SPL10076	BEKA-MAX STRAIGHT COUPLING	8
10	SPL10115	90 DEG ELBOW	6

Extended Sentry - ASM10308

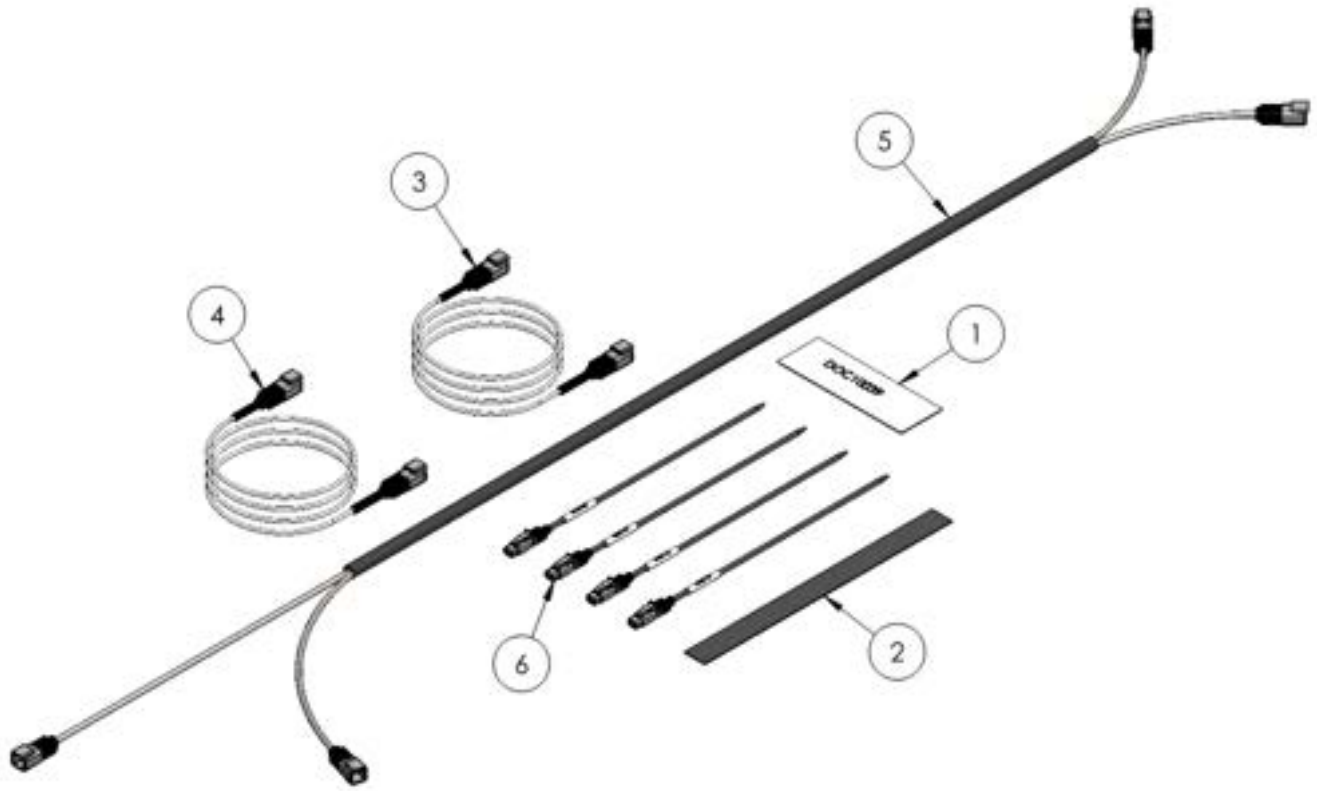

ITEM NO.	PART NUMBER	DESCRIPTION	QTY.
1	DOC10039	EXTENDED SENTRY INSTALLTION	1
2	PRT10613	ADHESIVE TAPE	1
3	SPL10230	LEFT HAND ACCELERATOR BEARING EXTENSION CABLE	1
4	SPL10231	RIGHT HAND ACCELERATOR BEARING EXTENSION CABLE	1
5	SPL10232	CUTTER HEAD BEARING EXTENSION CABLE	1
6	SPL10238	TEMPERATURE PROBE	4

Complete Roll Options

TC = TWIN CUT	
Part Number	Description
KMP20023-110-C	110 TC ROLL ASSY COMPLETE
KMP20024-145-C	145 TC ROLL ASSY COMPLETE
KMP20044-165-C	165 TC ROLL ASSY COMPLETE
ASM10278-110-C	110 TC GREASE ROLL ASSY COMPLETE
ASM10279-145-C	145 TC GREASE ROLL ASSY COMPLETE
ASM10314-165-C	165 TC GREASE ROLL ASSY COMPLETE

SAW = SAW TOOTH	
Part Number	Description
KMP20031-110-C	110 SAW ROLL ASSY COMPLETE
KMP20032-145-C	145 SAW ROLL ASSY COMPLETE
ASM10315-165-C	165 SAW ROLL ASSY COMPLETE
ASM10275-110-C	110 SAW GREASE ROLL ASSY COMPLETE
ASM10276-145-C	145 SAW GREASE ROLL ASSY COMPLETE
ASM10277-165-C	165 SAW GREASE ROLL ASSY COMPLETE



No Housing Roll Options

TC = TWIN CUT	
Part Number	Description
KMP20023-110-C-NH	110 TC ROLL ASSY NO HSNGS
KMP20024-145-C-NH	145 TC ROLL ASSY NO HSNGS
KMP20044-165-C-NH	165 TC ROLL ASSY NO HSNGS

SAW = SAW TOOTH	
Part Number	Description
KMP20031-110-C-NH	110 SAW ROLL ASSY NO HSNGS
KMP20032-145-C-NH	145 SAW ROLL ASSY NO HSNGS
ASM10315-165-C-NH	165 SAW ROLL ASSY NO HSNGS



Roll Assembly Parts List



ITEM NO.	PART NUMBER	DESCRIPTION	QTY.
1	BLT10030	SOCKET HEAD CAP SCREW	20
2	HOR1004.60	60 MM OUTSIDE HOUSING SEAL	1
3	HOR1004.70	70MM INSIDE HSG SEAL ASSY	2
4	HOR1007	60MM BEARING	2
5	HOR1014	H.O. ROLL SHAFT	1
6	HOR1016	ROLL TO SHAFT LOCKING HUB	2
7	HPR1009	FIBER OIL SEAL	6
8	JDRM2016	IDLE BEARING HOUSING ASSEMBLY	1
9	JDRM2018	DRIVE BEARING HOUSING ASSEMBLY	1
10	PRT10443	70mm SPOOL SEAL	2

*Taper lock comes with bolts. Item 1 can be purchased separately as a replacement part.



Saw Tooth Roll

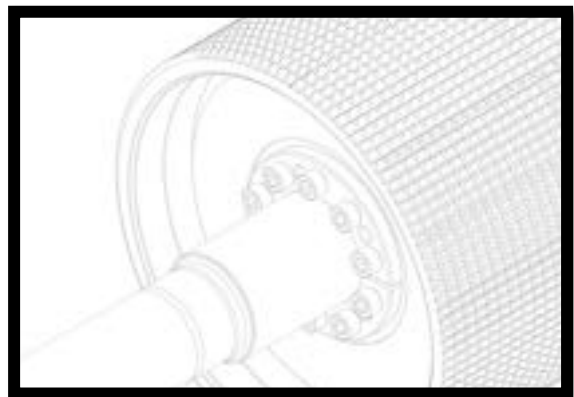

Twin Cut Roll

Housing Hardware

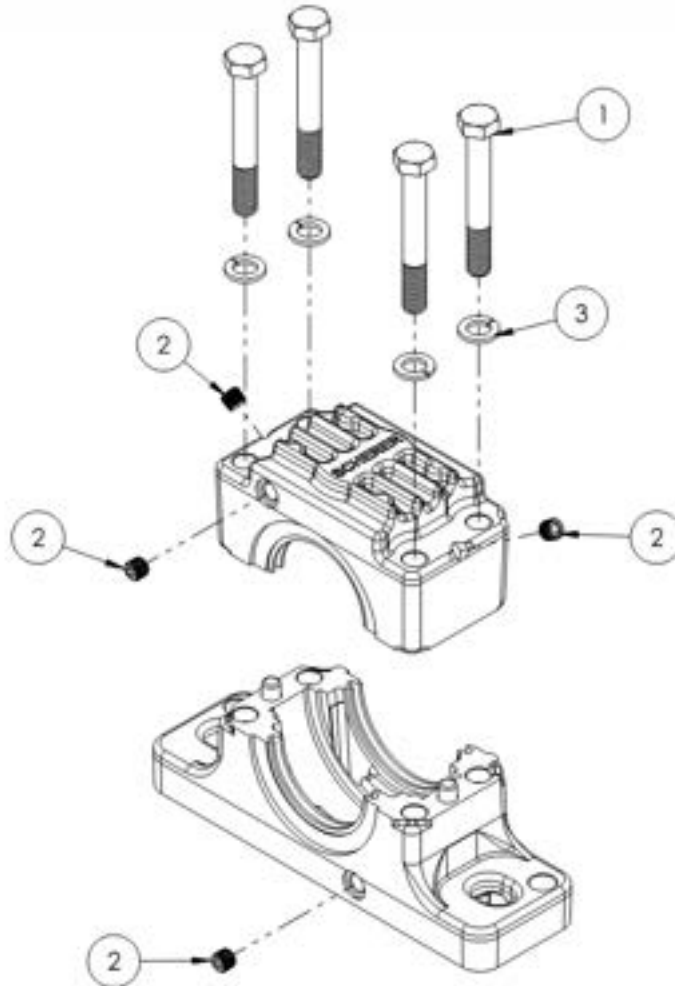

ITEM NO.	PART NUMBER	DESCRIPTION	QTY.
1	BLT10000	HEX HEAD BOLT	4
2	SPL10001	PLUG	4
3	WSH10000	LOCK WASHER	4



JDRM2018 - Drive side



JDRM2016 - Idle side

Bulb Seal Replacement Kit - HPTB1075

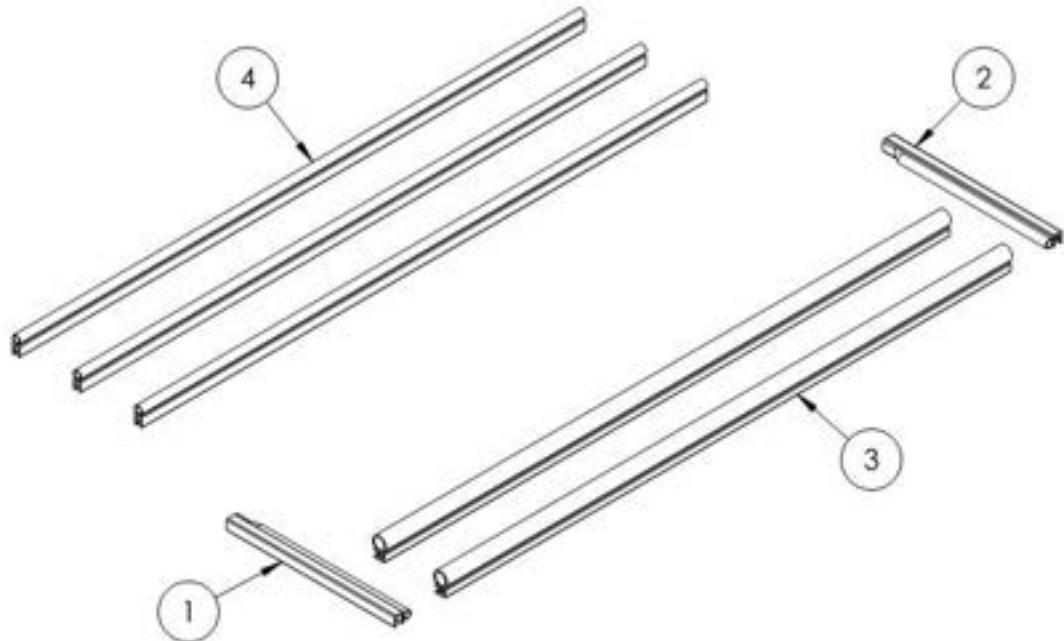

ITEM NO.	PART NUMBER	DESCRIPTION	QTY.
1	HPT1010L	LEFT SHROUD SEAL	1
2	HPT1010R	RIGHT SHROUD SEAL	1
3	T1054	5/8" 90 DEG BULB SEAL	2
4	TB1043	SHROUD SEAL	3

Cheek Plate Replacement Kit - ASM10317

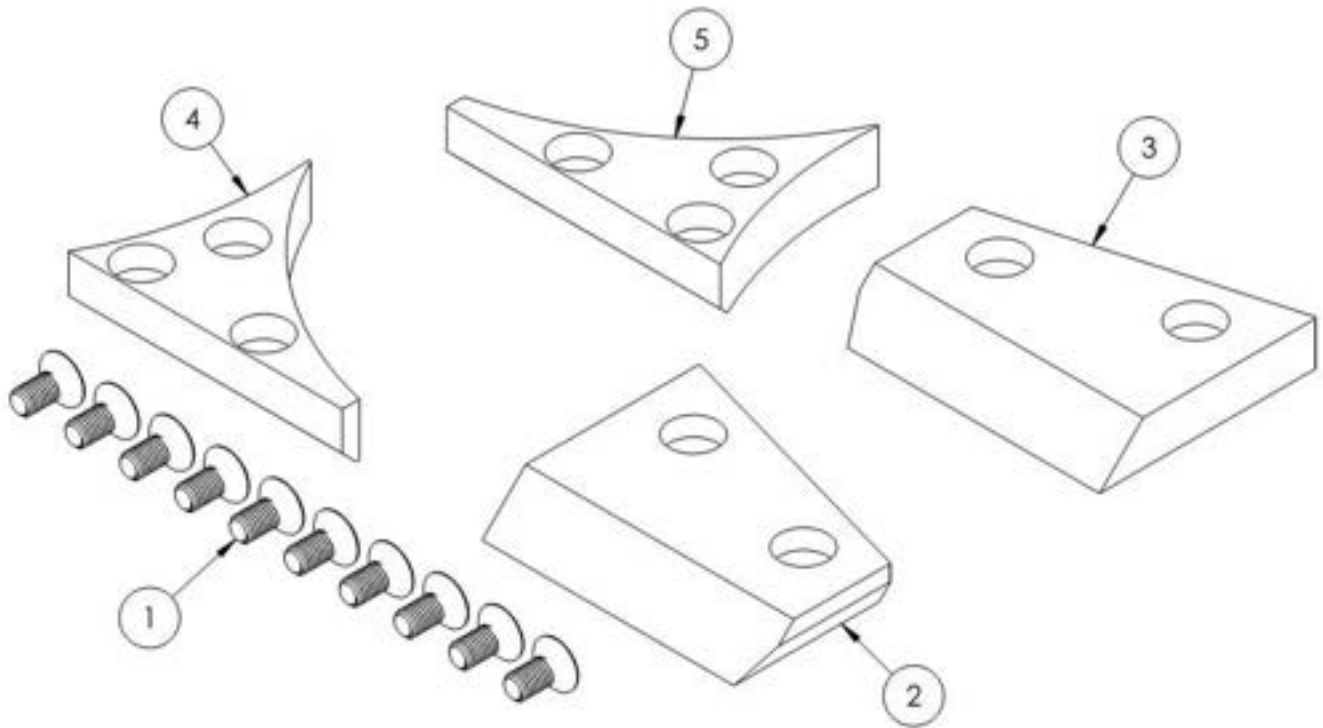

ITEM NO.	PART NUMBER	DESCRIPTION	QTY.
1	BLT10005	FLAT HEAD SCREW	10
2	KMP10041	IDLE SIDE CHEEK PLATE	1
3	KMP10042	DRIVE SIDE CHEEK PLATE	1
4	KMP10043	IDLE SIDE BOTTOM CHEEK PLATE	1
5	KMP10044	DRIVE SIDE BOTTOM CHEEK PLATE	1

Schermist® Parts List - Air Lubrication

ASM10016

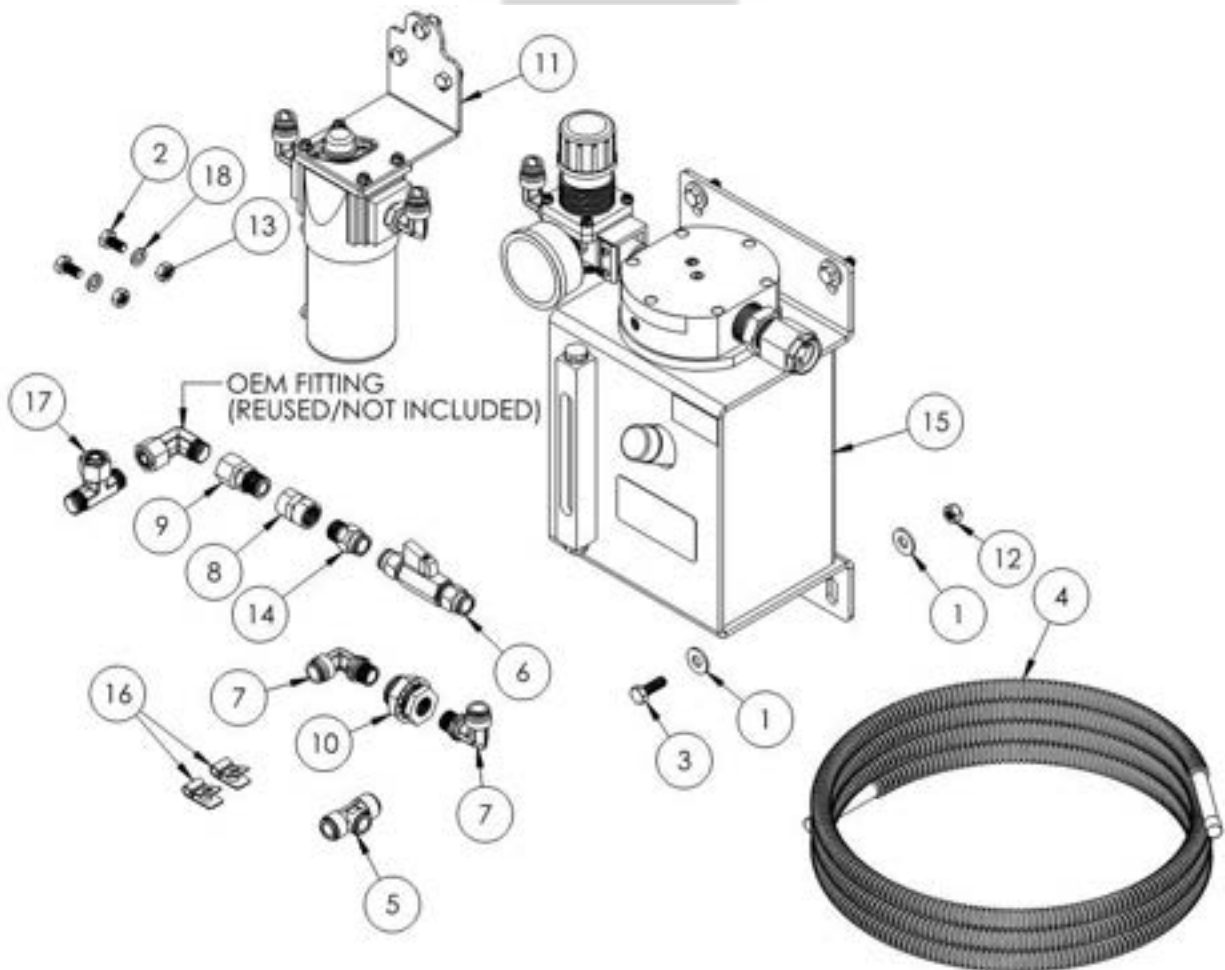

ITEM NO.	PART NUMBER	DESCRIPTION	QTY.
1	B1072	FLAT WASHER	8
2	BLT10042	HEX HEAD BOLT	2
3	BLT10043	HEX HEAD BOLT	4
4	D1348	12mm HOSE AND LOOM	1
5	HPD1349	T FITTING	1
6	HPD1359	12MM VALVE ASSEMBLY	1
7	HPD1420	90° PUSHLOCK	2
8	HPD1422	FEMALE PIPE UNION	1
9	HPD1423	CONVERSION FITTING	1
10	HPD1425	BULKHEAD FITTING	1
11	HPD1427	FILTER ASSEMBLY	1
12	NUT10009	LOCK NUT	4
13	NUT10010	HEX NUT	2
14	OM1025	PUSHLOCK FITTING	1
15	OM5021	OIL TANK ASSEMBLY	1
16	SPL10101	TUBE CLAMP	2
17	SPL10111	BRANCH TEE	1
18	WSH10002	LOCK WASHER	2

Filter Assembly

HPD1427

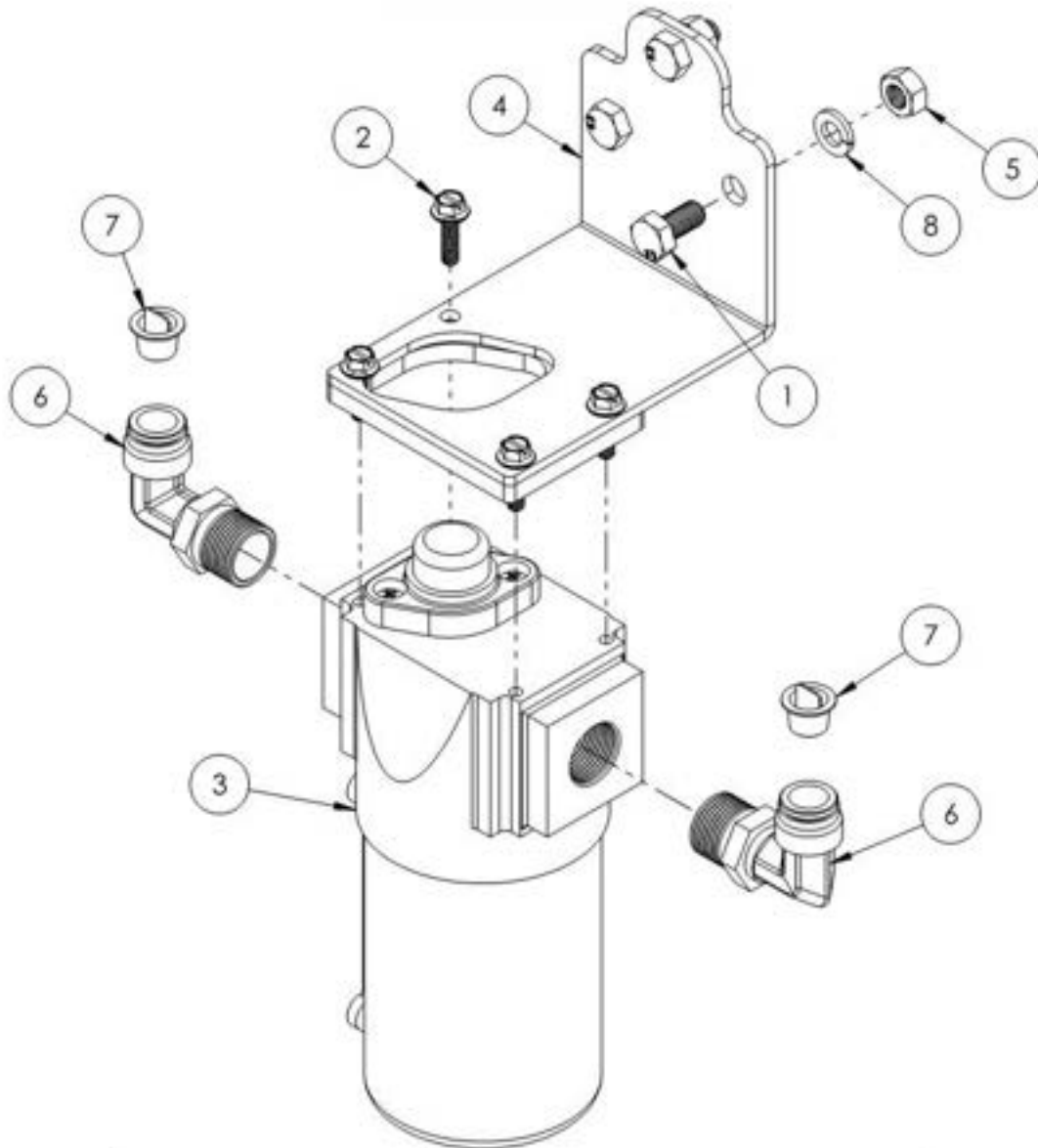

ITEM NO.	PART NUMBER	DESCRIPTION	QTY.
1	BLT10042	HEX HEAD BOLT	3
2	BLT10047	FLAT HEAD SCREW	4
3	HPD1411	FILTER	1
4	HPD1414	FILTER MOUNTING BRACKET	1
5	NUT10010	HEX NUT	3
6	OM1033	90° SWIVEL FITTING	2
7	SPL10161	FITTING PLUG	2
8	WSH10002	LOCK WASHER	3

Replacement Filter

HPD1411

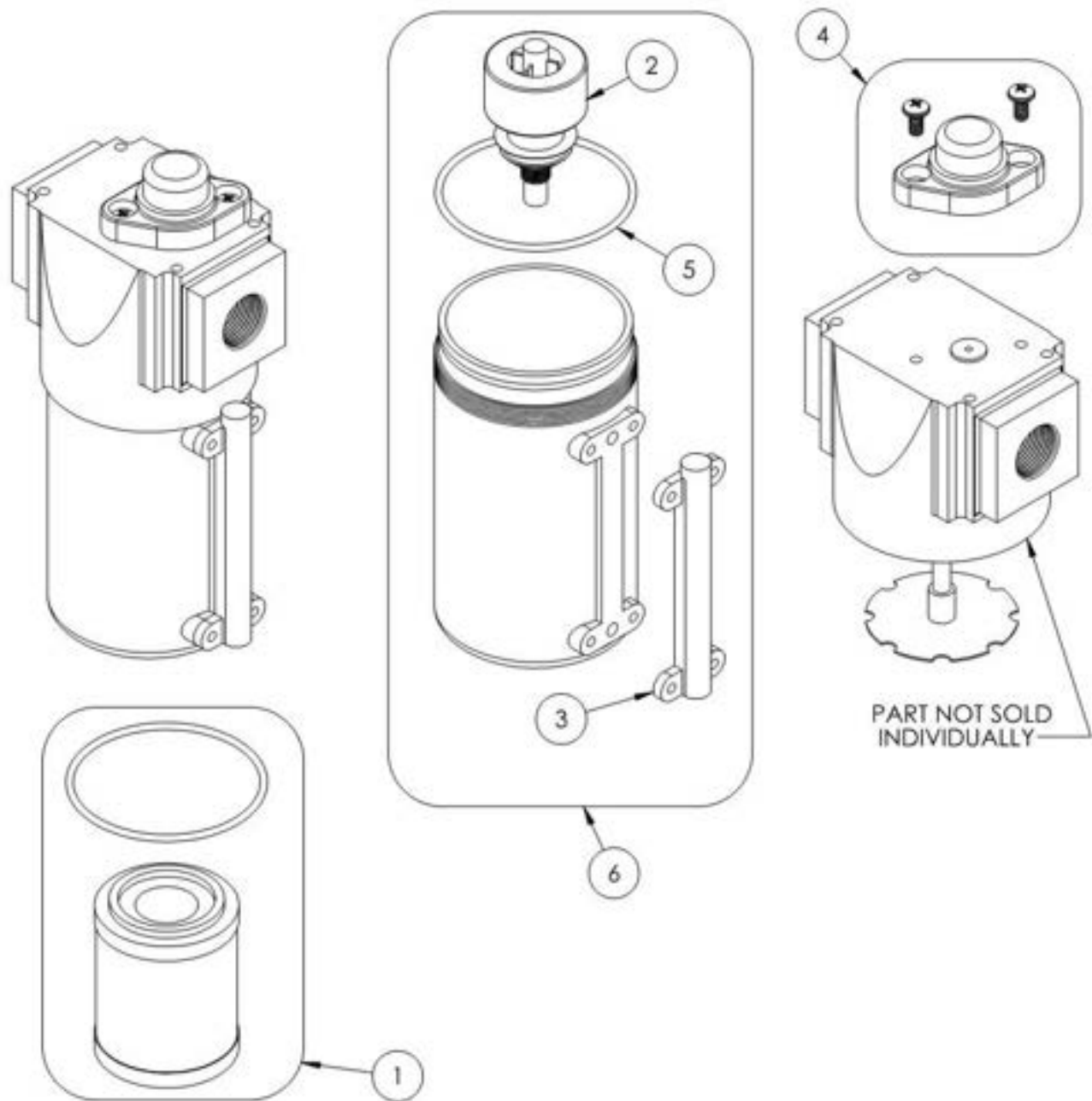

ITEM NO.	PART NUMBER	DESCRIPTION	QTY.
1	HPD1411.1	REPLACEMENT FILTER	1
2	HPD1411.4	FLOAT	1
3	HPD1411.5	COALESCING SIGHT GLASS KIT	1
4	HPD1411.6	INDICATOR POP-UP	1
5	HPD1411.7	BOWL O-RING	1
6	HPD1411.8	FILTER BOWL	1

OM5021

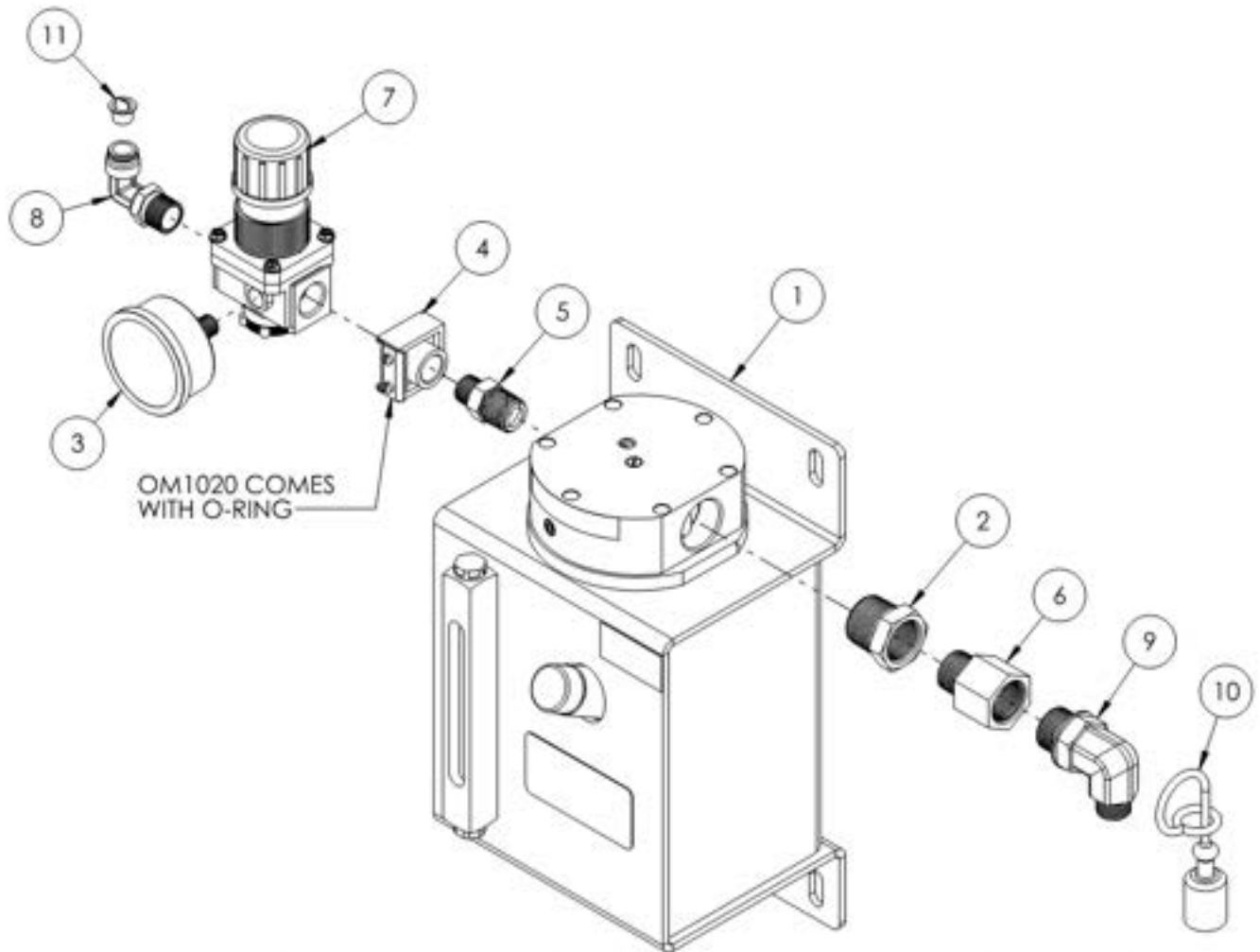

ITEM NO.	PART NUMBER	DESCRIPTION	QTY.
1	ASM10086	SCHERMIST RETRO	1
2	OM1003	STRAIGHT ADAPTER	1
3	OM1015	PRESSURE GUAGE	1
4	OM1020	PIPE PORT	1
5	OM1022	STRAIGHT REDUCER	1
6	OM1030	STRAIGHT ADAPTER	1
7	OM1032	REGULATOR	1
8	OM1033	90° SWIVEL FITTING	1
9	OM1034	90 DEGREE ADAPTER FITTING	1
10	SPL10027	FEMALE CAP	1
11	SPL10161	FITTING PLUG	1

ASM10086

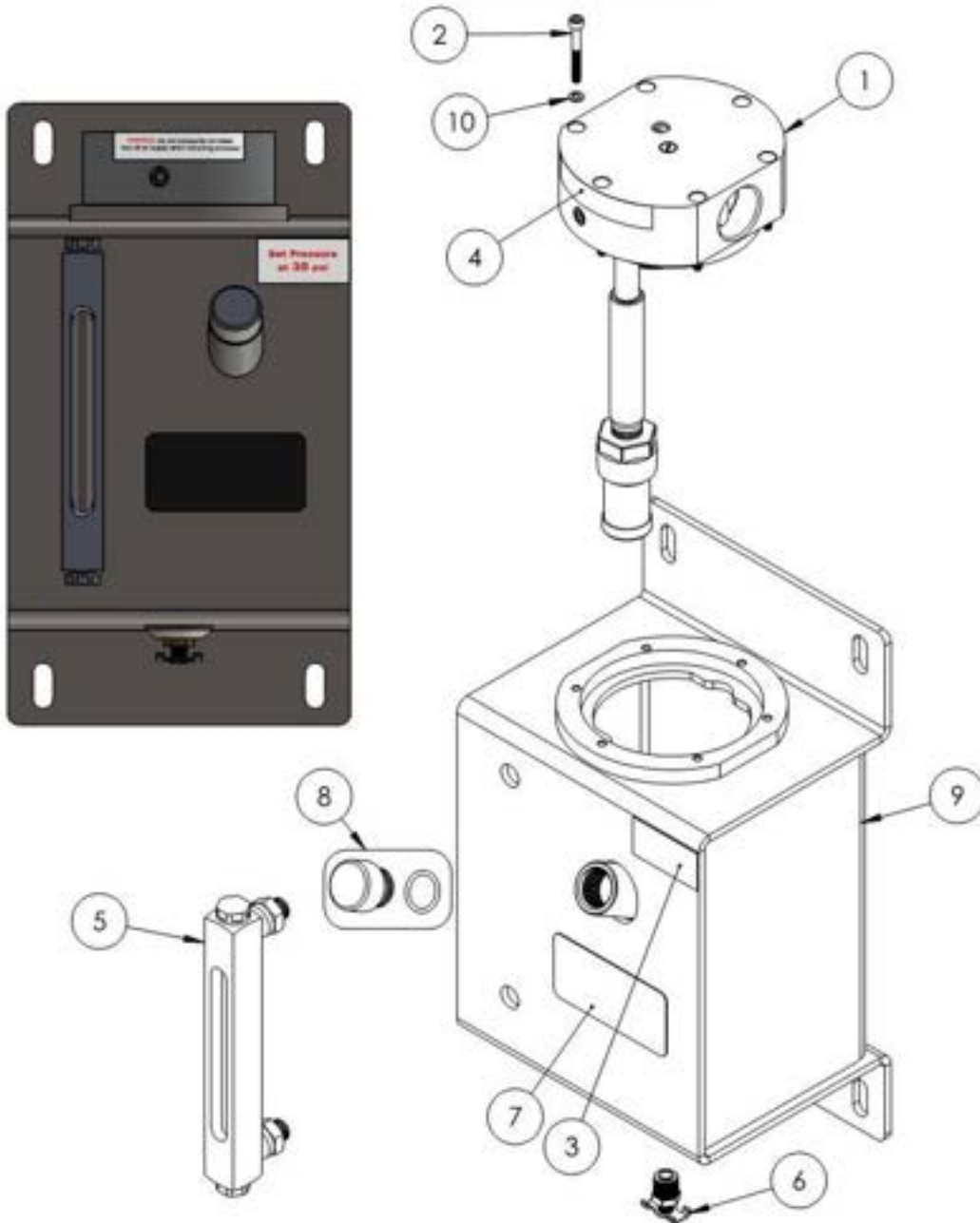

ITEM NO.	PART NUMBER	DESCRIPTION	QTY.
1	ASM10061	SCHERMIST HEAD ASSEMBLY	1
2	BLT10140	SOCKET HEAD SCREW	6
3	DEC1004	35PSI SET PRESSURE	1
4	DEC1007	WARNING : DO NOT OVER PRESSURIZE	1
5	OM1012	SIGHT GLASS	1
6	OM1039	STOP COCK DRAIN	1
7	OM1121	OIL TANK SERIAL PLATE	1
8	OM2026	CAP ASSEMBLY	1
9	OM5016	OIL RESEVOIR WLDMNT	1
10	WSH10006	LOCK WASHER	6

Schermist® Head Parts List

ASM10061

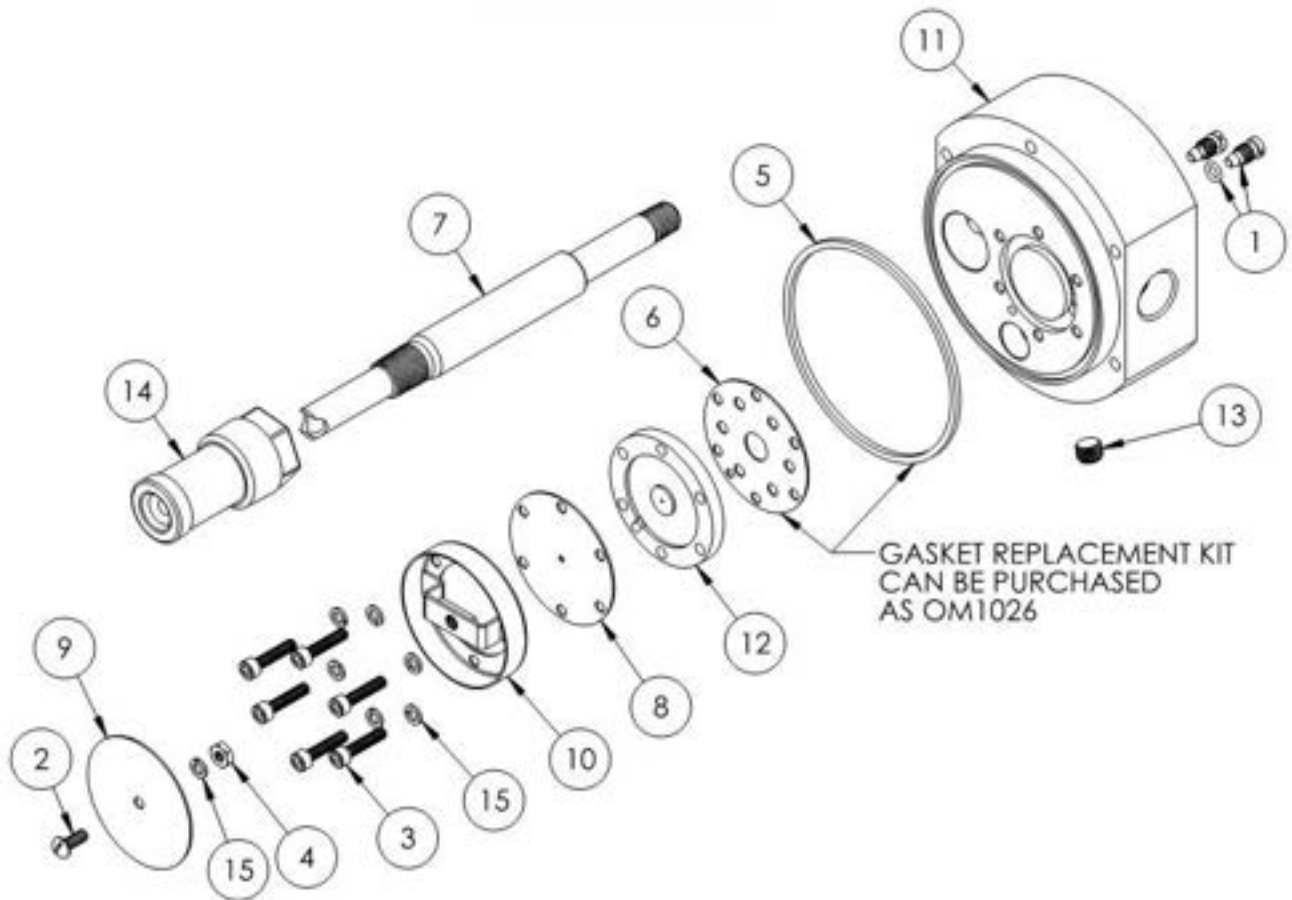

ITEM NO.	PART NUMBER	DESCRIPTION	QTY.
1	ASM10075	AIR SCREW ASSEMBLY	2
2	BLT10044	MACHINE SCREW	1
3	BLT10071	SOCKET HEAD CAP SCREW	6
4	NUT10011	MACHINE HEX NUT	1
5	OM1026.2	HEAD GASKET	1
6	OM1109	VENTURI GASKET	1
7	OM1114	STRAINER MNTG TUBE	1
8	OM2003	MISTER OIL PLATE	1
9	OM2008	IMPINGEMENT PLATE	1
10	OM2009	BAFFLE ASSEMBLY	1
11	OM2027	MISTER HEAD	1
12	PRT10262	VORTEX PLATE	1
13	R1235	PIPE PLUG	1
14	SPL10045	STRAINER	1
15	WSH10006	LOCK WASHER	7

ASM10179 - Grease Lubrication Kit



ITEM NO.	PART NUMBER	DESCRIPTION	QTY.
1	HPG1116	STRESS RELIEF LUBRICATION LINE	1
2	SPL10017	GREASE ZERK	1
3	SPL10084	REDUCER	1
4	SPL10170	FEMALE GREASE COUPLER	1
5	SPL10171	FEMALE GREASE COUPLER CAP	1
6	SPL10172	ADAPTOR FITTING	1
7	SPL10173	SEAL WASHER	1
8	SPL10252	TEE FITTING	1

ASM10180 - Manual Lubrication Kit

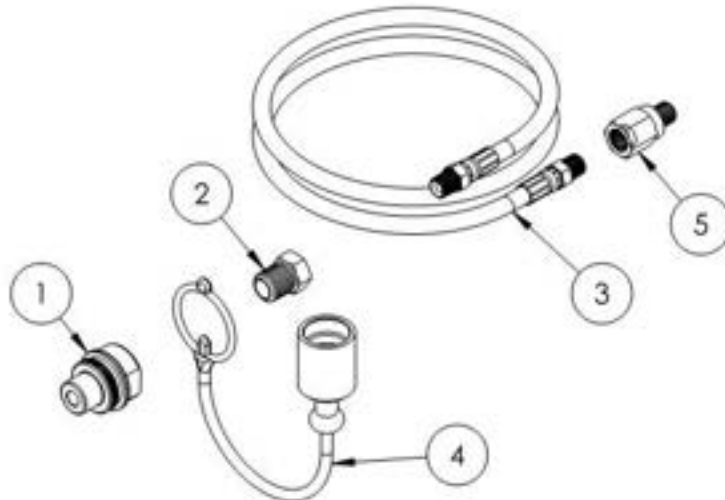

ITEM NO.	PART NUMBER	DESCRIPTION	QTY.
1	G1127-1	MALE NIPPLE	1
2	G1131	REDUCER	1
3	HPG1116	STRESS RELIEF LUBRICATION LINE	1
4	SPL10030	FEMALE DUST CAP	1
5	SPL10084	REDUCER	1

Manual Lubrication Parts List

ASM10006

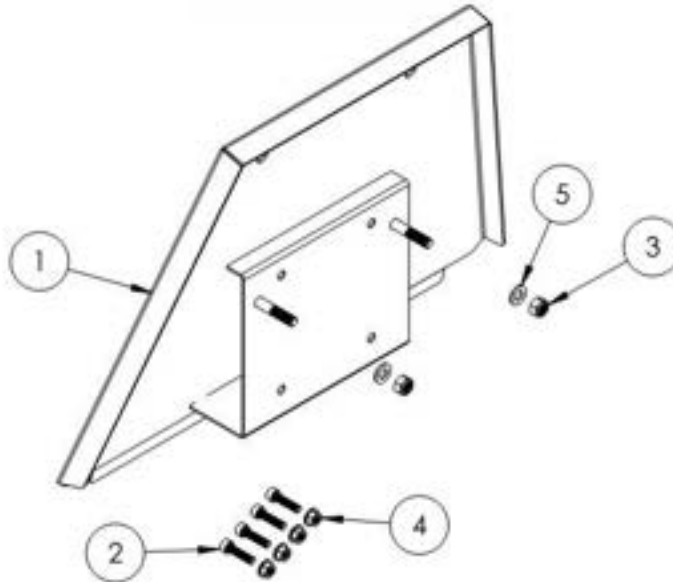

ITEM NO.	PART NUMBER	DESCRIPTION	QTY.
1	ASM10005	ELECTRIC LUBE MNTG BRACKET	1
2	BLT10058	SOCKET HEAD SCREW	4
3	NUT10009	LOCK NUT	2
4	NUT10034	FLANGE NUT	4
5	WSH10026	FLAT WASHER	2

ASM10108

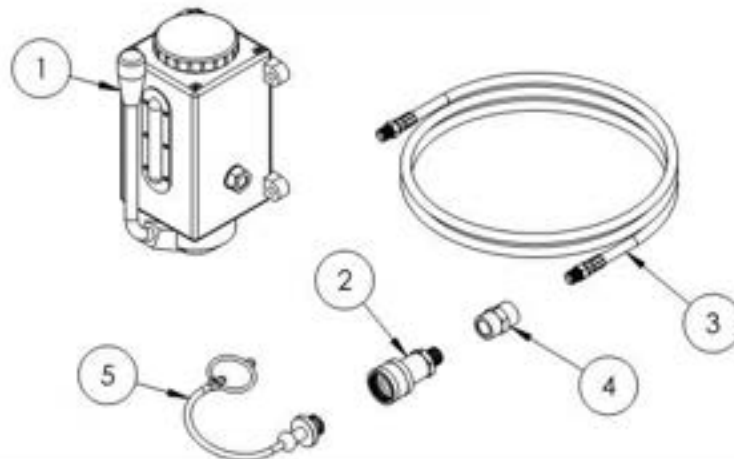

ITEM NO.	PART NUMBER	DESCRIPTION	QTY.
1	G1125	MANUAL OIL PUMP	1
2	G1128	FEMALE COUPLER	1
3	G1130	MAIN LUBRICATION LINE	1
4	G1148	REDUCER	1
5	SPL10134	MALE DUST CAP	1

7 Groove Drive Kit - ASM10021

1. Remove right front tire from the forage harvester.
2. Remove shield from wheel well.
3. Install grease tube (HOD1337) with the grease tube male adapters to the base of the idler shaft on the forage harvester. Then install the grease fitting (D1338). The grease tube will need to be bent and formed by hand to fit correctly. Fill the grease tube with grease using a grease gun till the grease comes out of the hole on the shaft.
4. Install main drive idle pulley assembly (HPD1410-7). The idle shaft will have to be cleaned and you may need to use emery cloth and a degreaser to ensure a smooth surface for the bearing to slide on. 3 spacers (D1334-7) are provided to be placed on the shaft prior to installing the idler pulley. The use of these spacers may depend on the alignment of the belt and pulley system. Spacers can be added or taken away as needed.
5. Install idler shaft cap (D1338-7) with a 16mm washer (D1327) and the mounting bolt (D1326). Torque to 231 Ft-lbs. (313 Nm). After the pulley is installed, give the grease zerk 2 pumps. The idler pulley comes pre-greased from the factory.
6. Install grooved main drive pulley (HOD1301) or (D1301-7) or (HPD1301-7.45). Again, the shaft will need to be cleaned with a degreaser and emery cloth may need to be used to get a clean and smooth surface to ensure a secure lock to the pulley. Place the main drive pulley onto the accelerator shaft with the locking hub still in place and align the main drive pulley to the lower idler pulley since the idler pulley is fixed. If proper alignment is not obtained, spacers (D1334-7) will need to be added or taken away to facilitate the proper alignment of the system. It is critical to obtain alignment $\pm 1/16$ in. After the pulleys have been properly aligned, the locking hub will need to be tightened. Torque bolts of the locking device to 32ft/lbs. Torque bolts in a clockwise rotation and go around the locking hub 3 to 4 times to ensure proper torque. Alignment can also be made easier by using a laser alignment tool (A0011) available through SCHERER INC.
7. Install the tension arm (HPD1307-7). The shaft may need to be cleaned and you may need to use emery cloth and a degreaser to ensure that the shaft is clean and smooth. The tension arm can be slid on to the shaft and washers (D1312) are provided for alignment as needed.
8. Install the pivot tube brace (HPD1373).
9. Mount the pneumatic cylinder bracket (HPD1346-7) in place of the spring tension bracket on the forage harvester. Bushings (D1323), a washer (D1324), and a snap ring (D1325-7) are provided if needed.
10. Install the pneumatic tension cylinder (HPD1341). The base of the cylinder should be connected to the pneumatic cylinder bracket (HPD1346-7) and the other end should be connected to the tension arm (HPD1307-7). Make sure that the swivel fittings (HPD1354) are facing the rear of the forage harvester when the pneumatic cylinder is installed. This allows for access to the cylinder and fittings from inside the forage harvester.
11. Set the processor pulleys to align with the drive system. Once the Scherer Processor is in place and properly aligned; the grooved processor pulley should be loosened and aligned with the main drive grooved pulley and the idle pulley. This alignment is very critical and should be within $\pm 1/16$ in. After the grooved processor pulley is in place, the smooth processor pulley can be aligned to the rest of the drive system. The locking hubs on the processor should be tightened the same way as the main drive pulley locking hub making sure that the shoulder of the locking hub is pressed firmly against the center disc of the pulley. Torque the locking hubs to 32 ft/lbs. 41). Torque in a clockwise pattern and go around tightening every bolt. Continue torquing in a clockwise pattern 3 to 4 times. This will ensure all bolts are at the appropriate torque.

6 Groove Drive Kit - ASM10020

1. Remove right front tire from the forage harvester.
2. Remove shield from wheel well.
3. Install grease tube (D1337) to the base of the idler shaft on the forage harvester. Then install the grease fitting (D1338). The grease tube will need to be bent and formed by hand in order to fit correctly. Fill the grease tube with grease using a grease gun till the grease comes out of the hole on the shaft.
4. Install main drive idle pulley assembly (HPD1410). The idle shaft will have to be cleaned and you may need to use emery cloth and a degreaser to ensure a smooth surface for the bearing to slide on. 3 spacers (D1334) are provided to be placed on the shaft prior to installing the idler pulley. The use of these spacers may depend on the alignment of the belt and pulley system. Spacers can be added or taken away as needed.
5. Install idler shaft cap (D1338) with a 16mm washer (D1327) and the mounting bolt (D1326). Torque to 161 Ft-lbs. (219 Nm). After the pulley is installed, give the grease zerk 2 pumps. The idler pulley comes pre-greased from the factory.
6. Install grooved main drive pulley. Again the shaft will need to be cleaned with a degreaser and emery cloth may need to be used to get a clean and smooth surface to ensure a secure lock to the pulley. Place the main drive pulley onto the accelerator shaft with the locking hub still in place and align the main drive pulley to the lower idler pulley since the idler pulley is fixed. If proper alignment is not obtained, spacers (D1334) will need to be added or taken away to facilitate the proper alignment of the system. It is critical to obtain alignment $\pm 1/16$ in. After the pulleys have been properly aligned, the locking hub will need to be tightened. Torque bolts of the locking device to 32 ft/lbs. Torque bolts in a clockwise rotation and go around the locking hub 3 to 4 times to ensure proper torque. Alignment can also be made easier by using a laser alignment tool (A0011) available through SCHERER INC.
7. Install the tension arm (HPD1307). The shaft may need to be cleaned and you may need to use emery cloth and a degreaser to ensure that the shaft is clean and smooth. The tension arm can be slid on to the shaft and washers (D1312) are provided for alignment as needed.
8. Mount the tension arm bracket (HPD1346-7) in place of the spring tension bracket on the forage harvester. Reuse the OEM bushings. The washer (D1324), and a snap ring (D1325-7) are provided if needed.
9. Install the pneumatic tension cylinder (HPD1341). The base of the cylinder should be connected to the pneumatic cylinder bracket (HPD1346-7) and the other end should be connected to the tension arm (HPD1307). Make sure that the swivel fittings (HPD1354) are facing the rear of the forage harvester when the pneumatic cylinder is installed. This allows for access to the cylinder and fittings from inside the forage harvester.
10. Set the processor pulleys to align with the drive system. Once the Scherer Processor is in place and properly aligned; the grooved processor pulley should be loosened and aligned with the main drive grooved pulley and the idle pulley. This alignment is very critical and should be within $\pm 1/16$ in. After the grooved processor pulley is in place, the smooth processor pulley can be aligned to the rest of the drive system. The locking hubs on the processor should be tightened the same way as the main drive pulley locking hub making sure that the shoulder of the locking hub is pressed firmly against the center disc of the pulley. Torque the locking hubs to 32 ft/lbs. 41). Torque in a clockwise pattern and go around tightening every bolt. Continue torquing in a clockwise pattern 3 to 4 times. This will ensure all bolts are at the appropriate torque.

494 - 497 Air Retro 7 Groove

ASM10021

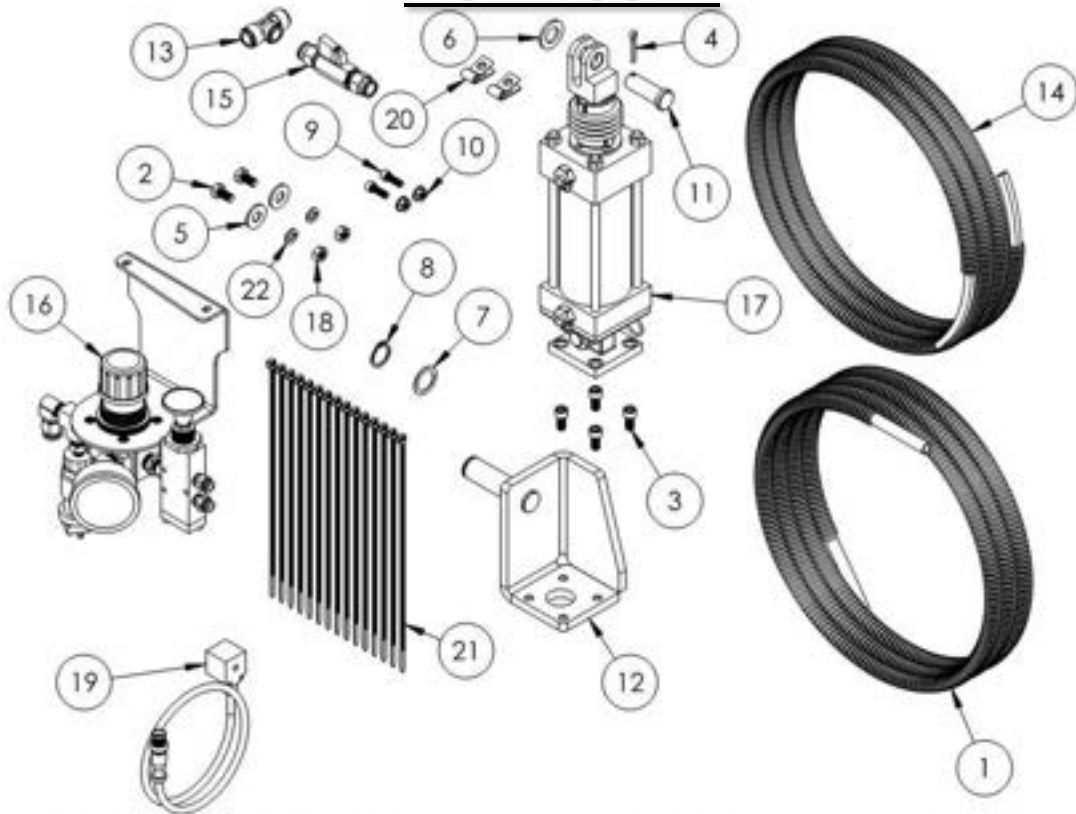

ITEM NO.	PART NUMBER	DESCRIPTION	QTY.
1	ASM10029	12mm HOSE AND LOOM	1
2	BLT10042	HEX HEAD BOLT	2
3	BLT10126	SOCKET CAP SCREW	4
4	D1315	COTTER PIN	1
5	D1316	FLAT WASHER	2
6	D1316-7	FLAT WASHER	1
7	D1324	SHIM RING	1
8	D1325-7	RETAINING RING	1
9	G1135	SOCKET HEAD SCREW	2
10	G1136	FLANGE NUT	2
11	HPD1314-7	CLEVIS PIN	1
12	HPD1346-7	7GR AIR CYL BRKT WLDMNT	1
13	HPD1349	T FITTING	1
14	HPD1352	AIR HOSE ASSY	1
15	HPD1359	12MM VALVE ASSEMBLY	1
16	HPD1385	PRESS REGLTR & ACTUATOR ASSY	1
17	HPD1398-7	4" AIR COMPLETE KIT	1
18	NUT10010	HEX NUT	2
19	PM3020	AIR PRESSURE MONITORING CABLE	1
20	SPL10101	TUBE CLAMP	2
21	SPL10102	11" BLACK CABLE TIE	15
22	WSH10002	LOCK WASHER	2

HPD1385

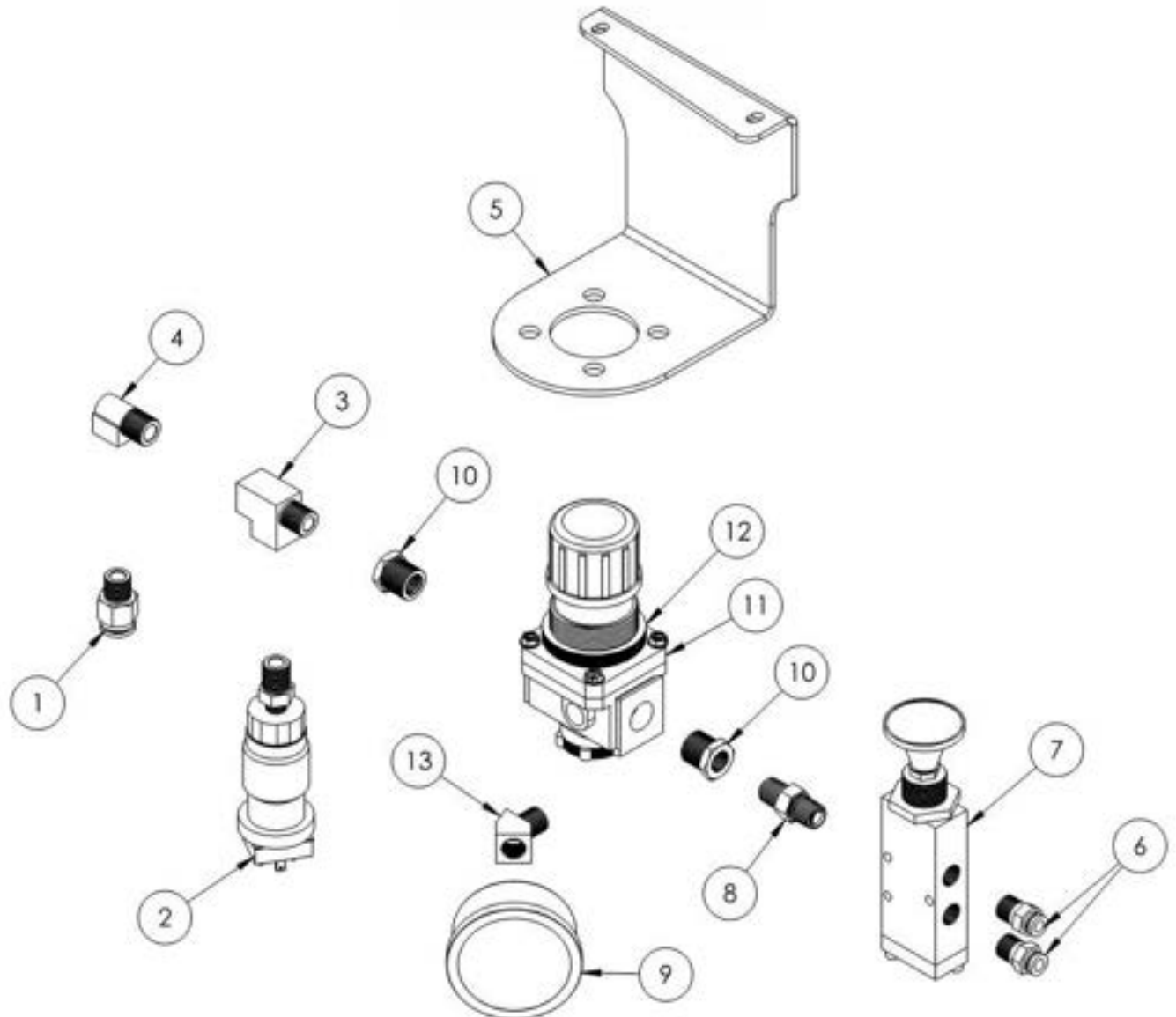

ITEM NO.	PART NUMBER	DESCRIPTION	QTY.	APPLY
1	HPD1358	FITTING	1	PTFE TAPE
2	HPD1370	AIR PRESSURE SENSOR	1	
3	HPD1371	AIR PRESSURE SENSOR TEE	1	PTFE TAPE
4	HPD1402	FITTING	1	PTFE TAPE
5	HPD1403	AIR REGULATOR MOUNT	1	
6	HPD1406	PUSH-LOC FITTING	2	PTFE TAPE
7	HPD1407	AIR VALVE ASSEMBLY	1	
8	HPD1408	HEX NIPPLE	1	PTFE TAPE
9	OM1015	PRESSURE GUAGE	1	
10	OM1021	REDUCER	2	PTFE TAPE
11	OM1023	REGULATOR	1	
12	OM1023.2	AIR REGULATOR RING	1	
13	OM1024	FITTING	1	PTFE TAPE

HPD1398-7

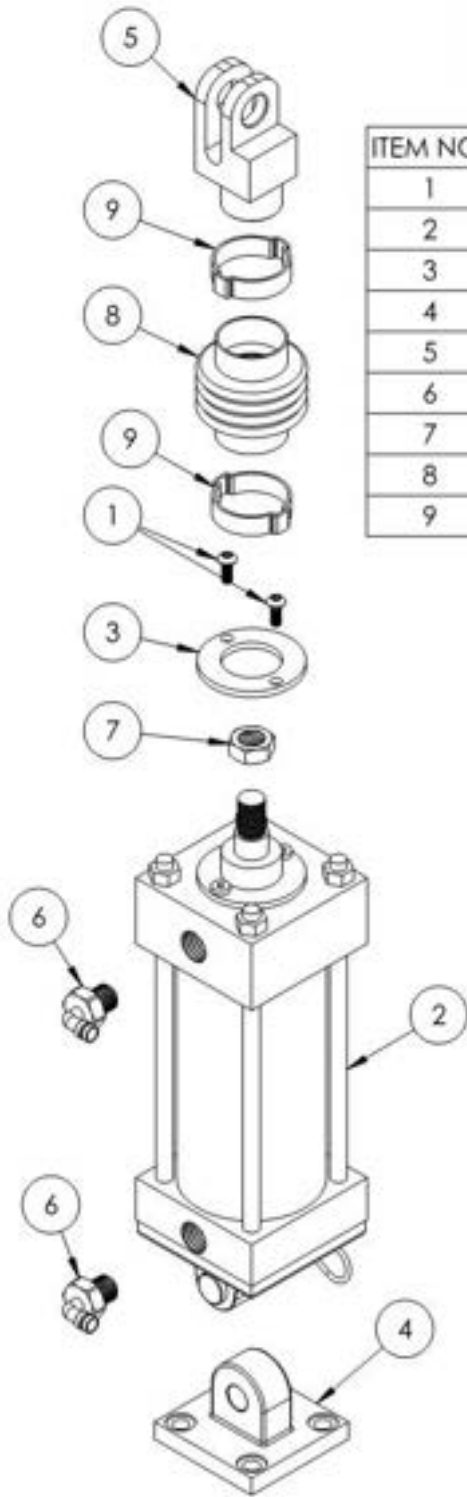

ITEM NO.	PART NUMBER	DESCRIPTION	QTY.
1	BLT10125	SOCKET CAP SCREW	2
2	HPD1341	PNEUMATIC CYLINDER	1
3	HPD1341.2B	AIR CYLINDER KEEPER	1
4	HPD1344	PNEUMATIC CYLINDER MALE CLEVIS	1
5	HPD1353-7	PNEUMATIC CYLINDER FORK	1
6	HPD1354	SWIVEL FIT	2
7	HPD1391	JAM NUT	1
8	HPD1396	BELLOW	1
9	HPD1399	BELLOW CLIP	2

PARKER REBUILD KIT = HPD1341-1



NO-PAK REBUILD KIT = HPD1341-3



7 Groove Tension Arm

ASM10024

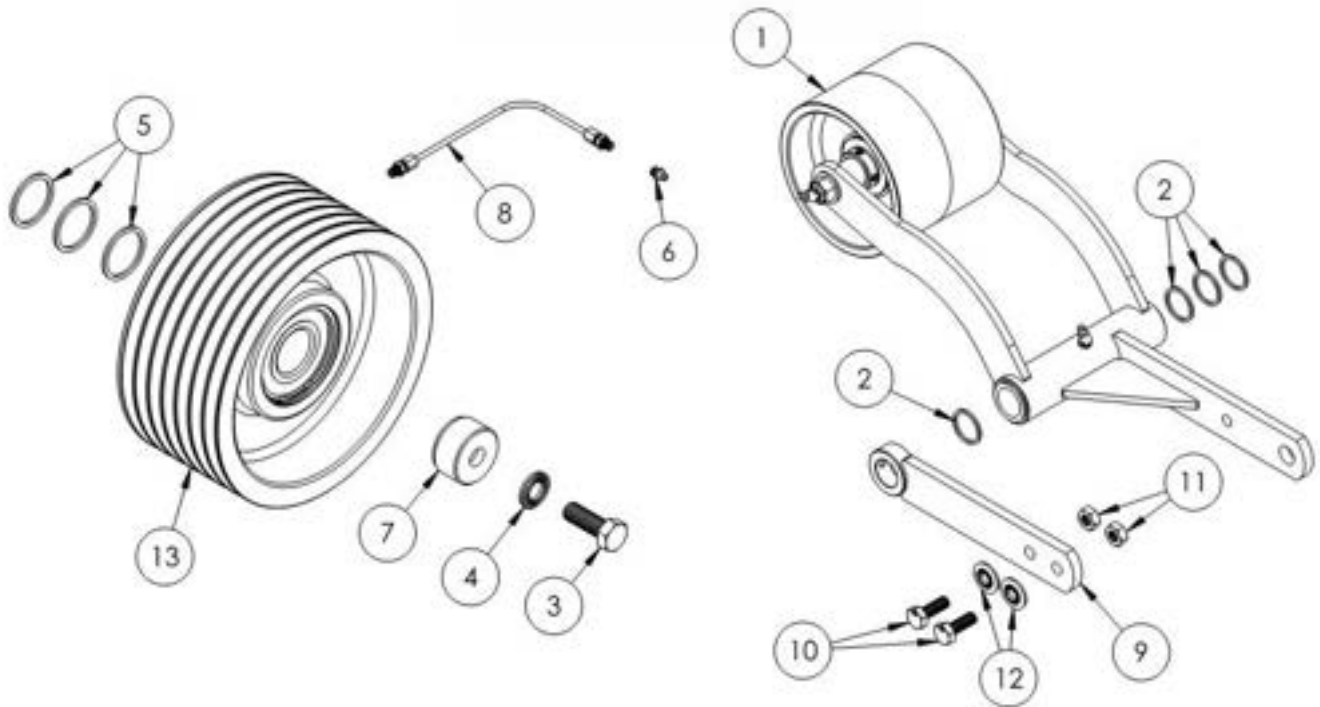

ITEM NO.	PART NUMBER	DESCRIPTION	QTY.
1	ASM10034	7GR TENSION ARM ASSY	1
2	D1312	FLAT WASHER	4
3	D1326	HEX HEAD BOLT	1
4	D1327	LOCK WASHER	1
5	D1334-7	SHIM	3
6	D1338	GREASE ZERK	1
7	D1338-7	IDLER SHAFT CAP	1
8	HOD1337	GREASE TUBE ASSY	1
9	HPD1373	PIVOT TUBE BRACE WLDMNT	1
10	HPD1374	HEX HEAD BOLT	2
11	HPD1375	HEX NUT	2
12	HPD1376	LOCK WASHER	2
13	HPD1410-7	COMPLETE 7 GROOVE IDLER PULLEY	1

ASM10034

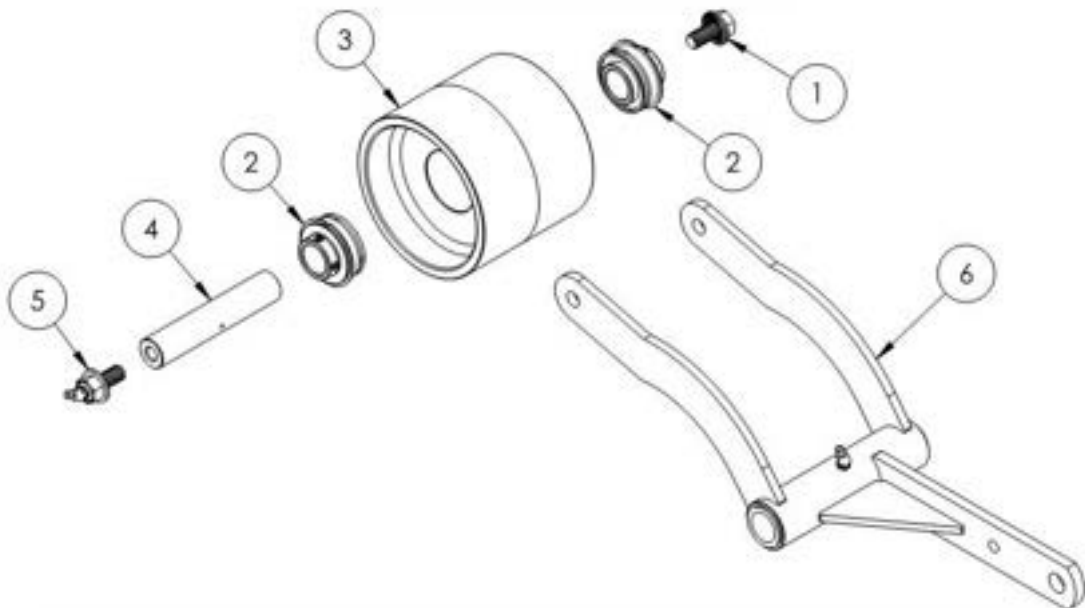

ITEM NO.	PART NUMBER	DESCRIPTION	QTY.
1	D1303	FLANGE BOLT	1
2	D1304	TENSION PULLEY BEARING	2
3	D1305-7	DRIVE TENSION PULLEY	1
4	D1308-7	7GR TENSION PULLEY SHAFT	1
5	D1309	TENSION ARM LUBE BOLT ASSY	1
6	HPD1307-7	TENSION ARM 7GR ASSY	1

HPD1410-7

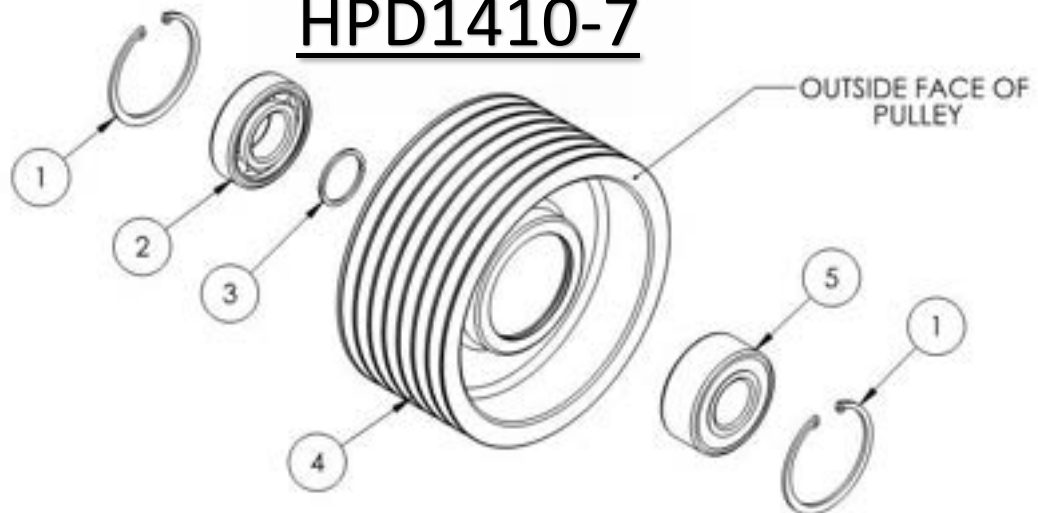

ITEM NO.	PART NUMBER	DESCRIPTION	QTY.
1	D1329-7	RETAINING RING	2
2	D1330-7	INNER BEARING	1
3	D1331-7	BEARING SHIM W/OILING SLOTS	1
4	D1332-7	7 GROOVE IDLER PULLEY	1
5	D1333-7	OUTER BEARING	1

494 - Air Retro 6 Groove

ASM10020

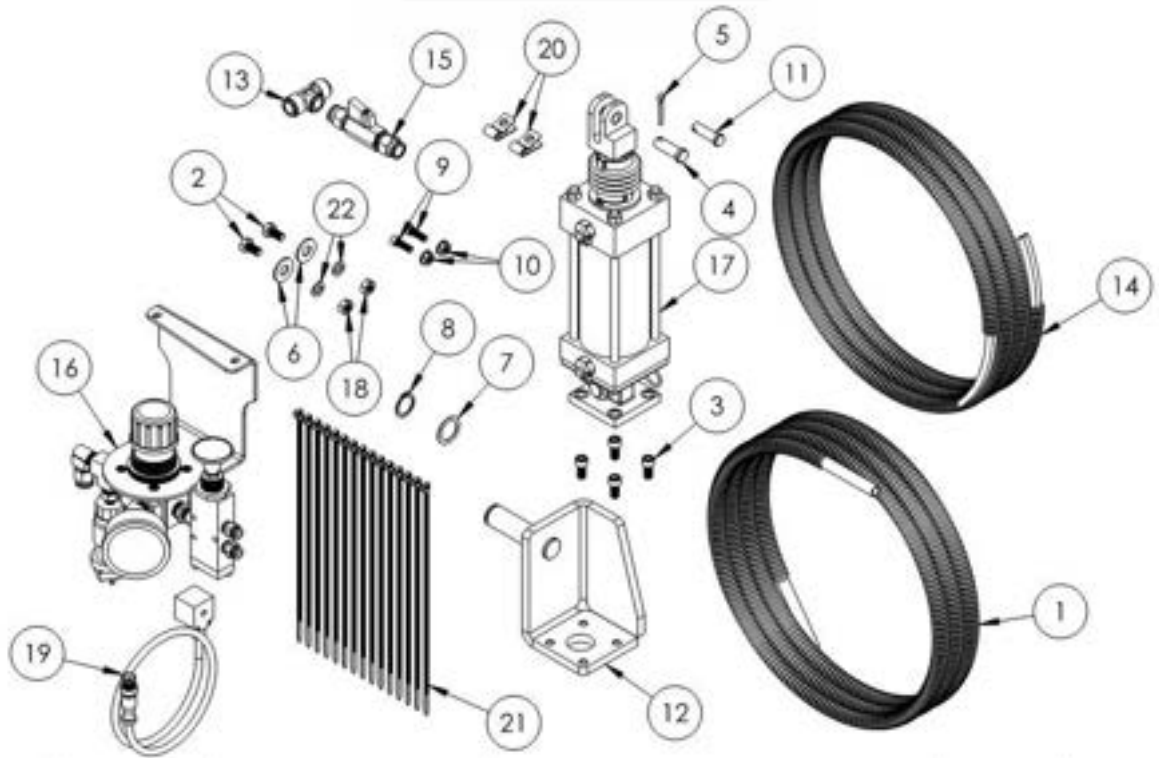

ITEM NO.	PART NUMBER	DESCRIPTION	QTY.
1	ASM10029	12mm HOSE AND LOOM	1
2	BLT10042	HEX HEAD BOLT	2
3	BLT10126	SOCKET CAP SCREW	4
4	D1314	CLEVIS PIN	1
5	D1315	COTTER PIN	1
6	D1316	FLAT WASHER	2
7	D1324	SHIM RING	1
8	D1325-7	RETAINING RING	1
9	G1135	SOCKET HEAD SCREW	2
10	G1136	FLANGE NUT	2
11	HPD1314-1	CLEVIS PIN	1
12	HPD1346-7	7GR AIR CYL BRKT WLDMNT	1
13	HPD1349	T FITTING	1
14	HPD1352	AIR HOSE ASSY	1
15	HPD1359	12MM VALVE ASSEMBLY	1
16	HPD1385	PRESS REGLTR & ACTUATOR ASSY	1
17	HPD1398	4" AIR COMPLETE KIT	1
18	NUT10010	HEX NUT	2
19	PM3020	AIR PRESSURE MONITORING CABLE	1
20	SPL10101	TUBE CLAMP	2
21	SPL10102	11" BLACK CABLE TIE	15
22	WSH10002	LOCK WASHER	2

HPD1398

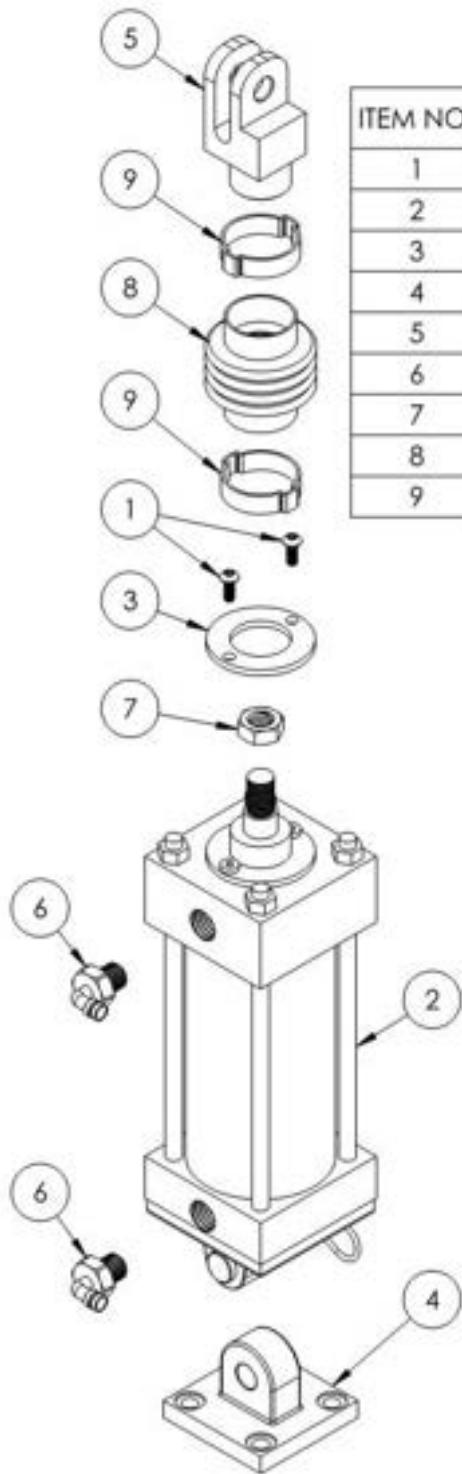

ITEM NO.	PART NUMBER	DESCRIPTION	QTY.
1	BLT10125	SOCKET CAP SCREW	2
2	HPD1341	PNEUMATIC CYLINDER	1
3	HPD1341.2B	AIR CYLINDER KEEPER	1
4	HPD1344	PNEUMATIC CYLINDER MALE CLEVIS	1
5	HPD1353	PNEUMATIC CYLINDER FORK	1
6	HPD1354	SWIVEL FIT	2
7	HPD1391	JAM NUT	1
8	HPD1396	BELLOW	1
9	HPD1399	BELLOW CLIP	2

PARKER REBUILD KIT = HPD1341-1



NO-PAK REBUILD KIT = HPD1341-3



6 Groove Tension Arm

ASM10023

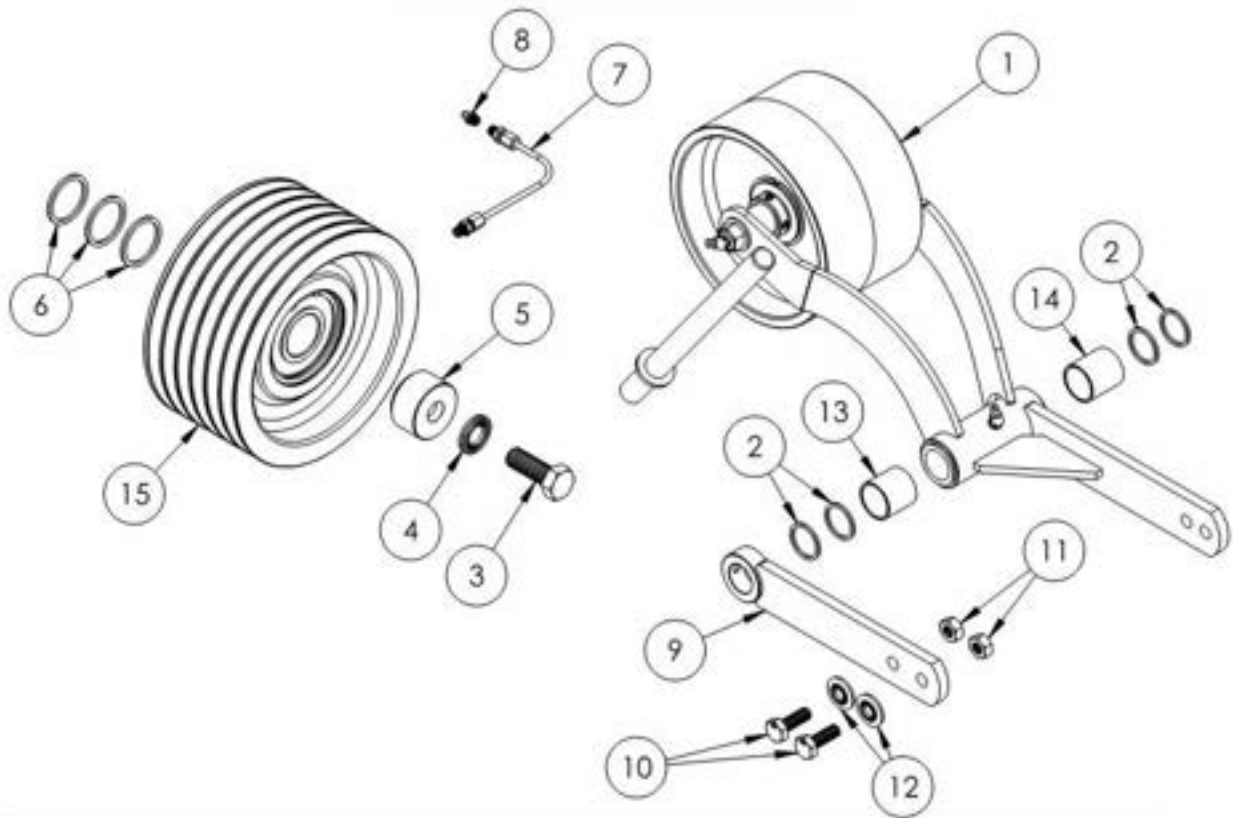

ITEM NO.	PART NUMBER	DESCRIPTION	QTY.
1	ASM10036	HP 6GR TENSION ARM ASSY	1
2	D1312	FLAT WASHER	4
3	D1326	HEX HEAD BOLT	1
4	D1327	LOCK WASHER	1
5	D1328	IDLE SHAFT CAP FOR 6GR	1
6	D1334	SHIM	3
7	D1337	GREASE TUBE ASSY	1
8	D1338	GREASE ZERK	1
9	HPD1373	PIVOT TUBE BRACE WLDMNT	1
10	HPD1374	HEX HEAD BOLT	2
11	HPD1375	HEX NUT	2
12	HPD1376	LOCK WASHER	2
13	HPD1386	SHORT TENSIONER SPACER	1
14	HPD1387	LONG TENSIONER SPACER	1
15	HPD1410	COMPLETE 6 GROOVE IDLER PULLEY	1

ASM10036

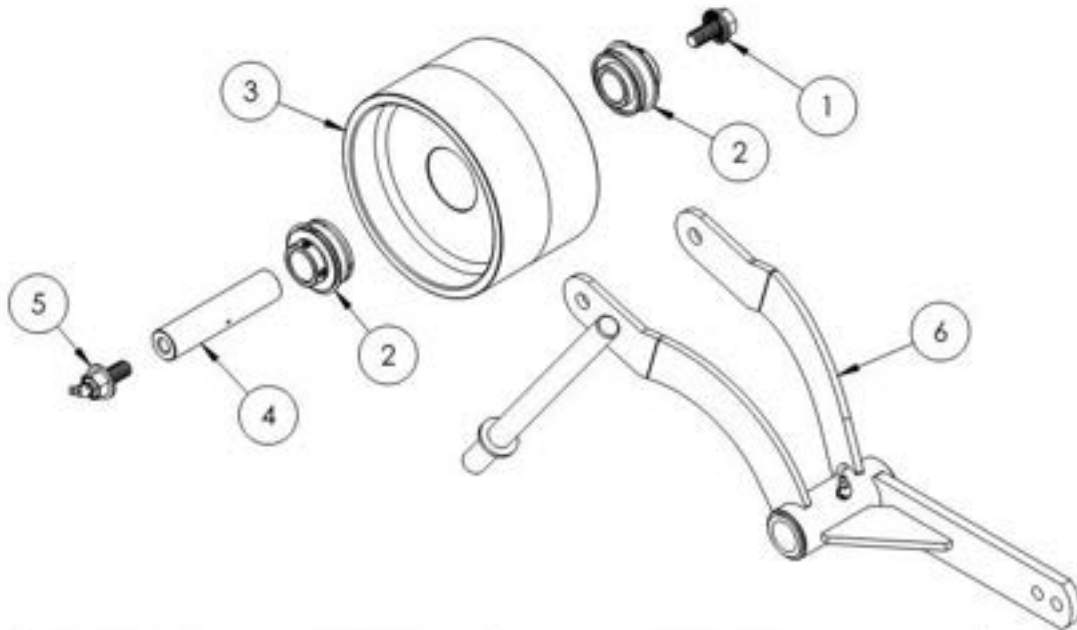

ITEM NO.	PART NUMBER	DESCRIPTION	QTY.
1	D1303	FLANGE BOLT	1
2	D1304	TENSION PULLEY BEARING	2
3	D1305S	HPS TENSION PULLEY	1
4	D1308	6GR TENSION PULLEY SHAFT	1
5	D1309	TENSION ARM LUBE BOLT ASSY	1
6	HPD1307	HP 6GR TENSION ARM ASSY	1

HPD1410

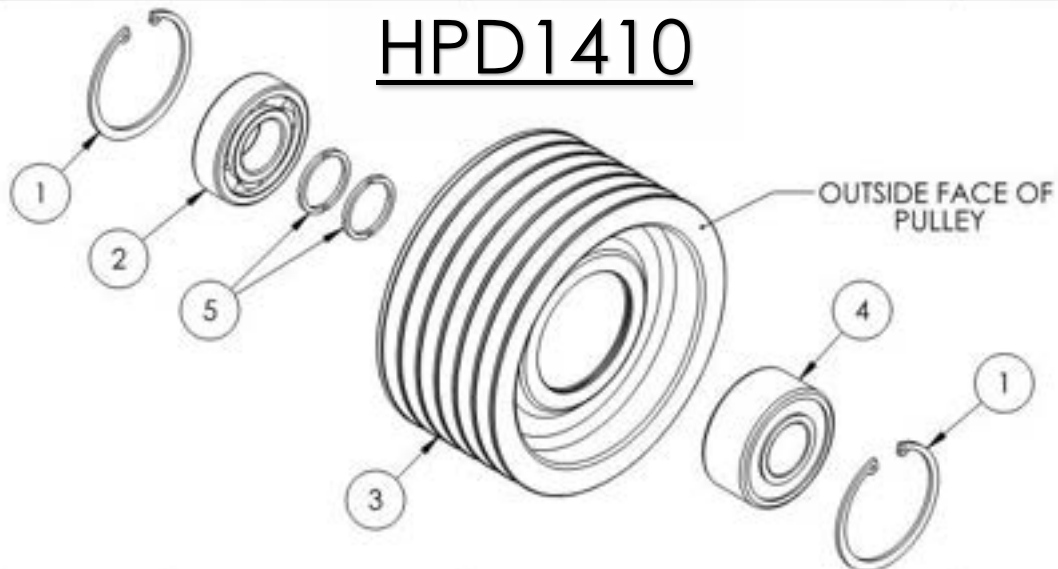

ITEM NO.	PART NUMBER	DESCRIPTION	QTY.
1	D1329	RETAINING RING	2
2	D1330	INNER BEARING	1
3	D1332	6 GROOVE IDLE PULLEY	1
4	D1333	SEALED DOUBLE ROLLER BEARING	1
5	PRT10047	BEARING SHIM W/OILING SLOTS	2

7 Groove Accelerator Pulley Parts

Bolts are included with locking hub. Called out for replacement only.

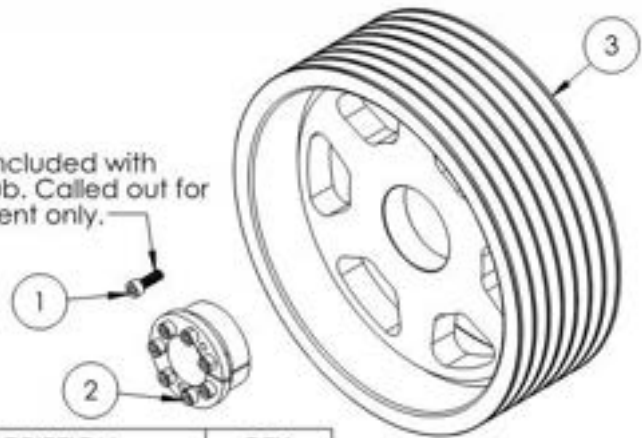

45mm Accelerator Shaft

ITEM NO.	PART NUMBER	DESCRIPTION	QTY.
1	BLT10107	SOCKET HEAD CAP SCREW	1
2	D1302	45mm LOCKING HUB	1
3	HPD1301-7.45	45mm 7GR DRIVE PULLEY	1

Bolts are included with locking hub. Called out for replacement only.

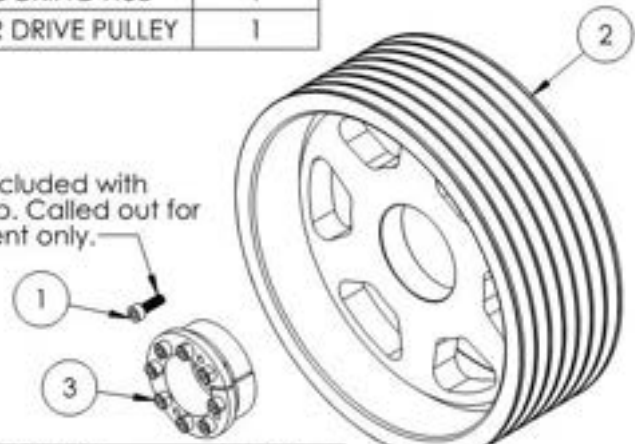

55mm Accelerator Shaft

ITEM NO.	PART NUMBER	DESCRIPTION	QTY.
1	BLT10107	SOCKET HEAD CAP SCREW	1
2	D1301-7	55mm 7GR DRIVE PULLEY	1
3	D1302-7	55mm LOCKING HUB	1

Bolts are included with locking hub. Called out for replacement only.

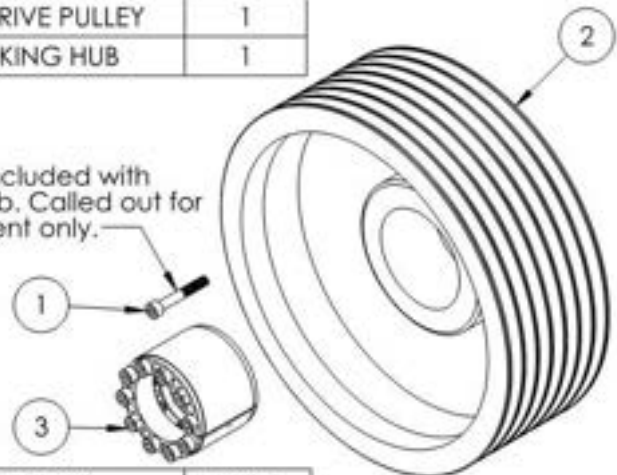

60mm Accelerator Shaft

ITEM NO.	PART NUMBER	DESCRIPTION	QTY.
1	BLT10163	SOCKET HEAD CAP SCREW	1
2	HOD1301	60mm DRIVE PULLEY	1
3	HOD1302	60mm LOCKING HUB	1

6 Groove Accelerator Pulley Parts

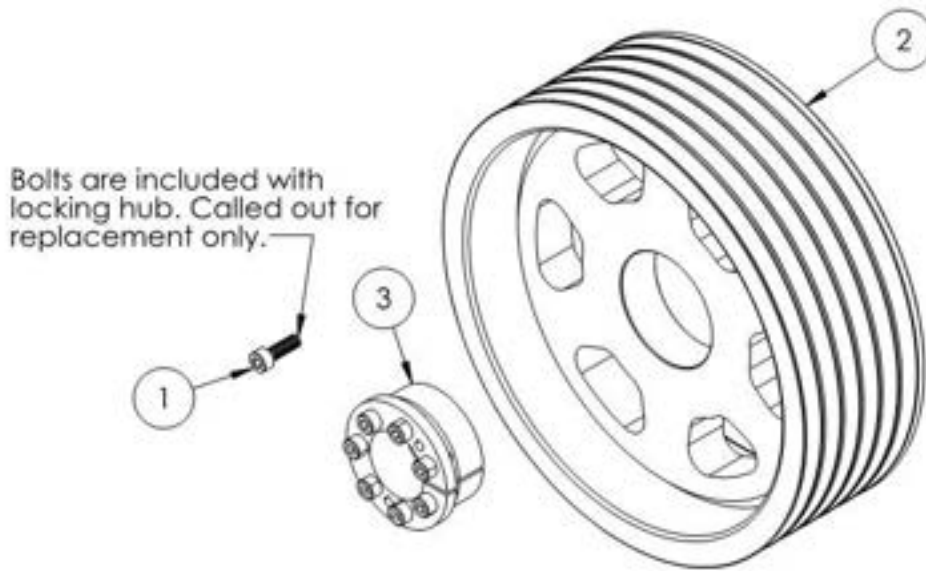

45mm Accelerator Shaft

ITEM NO.	PART NUMBER	DESCRIPTION	QTY.
1	BLT10107	SOCKET HEAD CAP SCREW	1
2	D1301	45mm 6GR DRIVE PULLEY	1
3	D1302	45mm LOCKING HUB	1

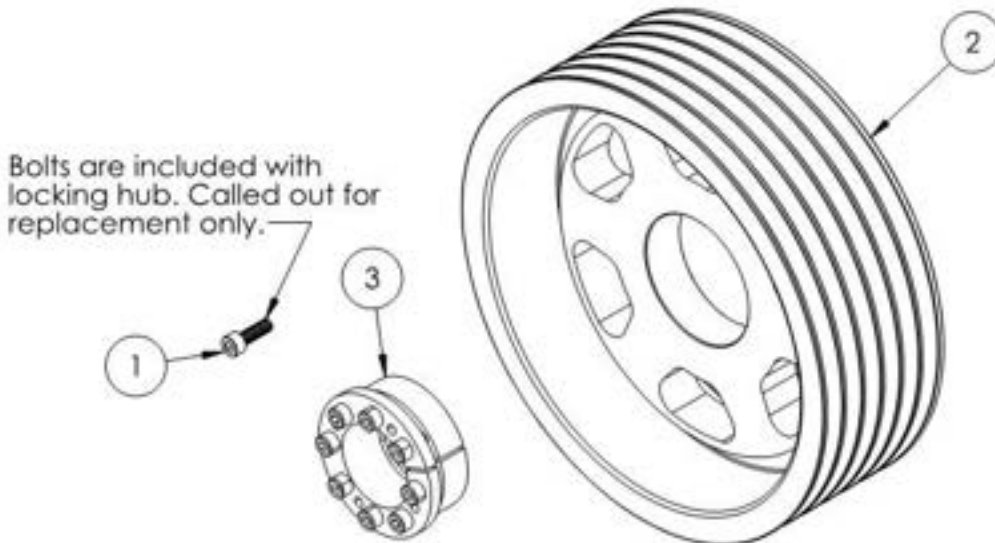

55mm Accelerator Shaft

ITEM NO.	PART NUMBER	DESCRIPTION	QTY.
1	BLT10107	SOCKET HEAD CAP SCREW	1
2	D1301.55	55mm 6GR DRIVE PULLEY	1
3	D1302-7	55mm LOCKING HUB	1

Decal Layout

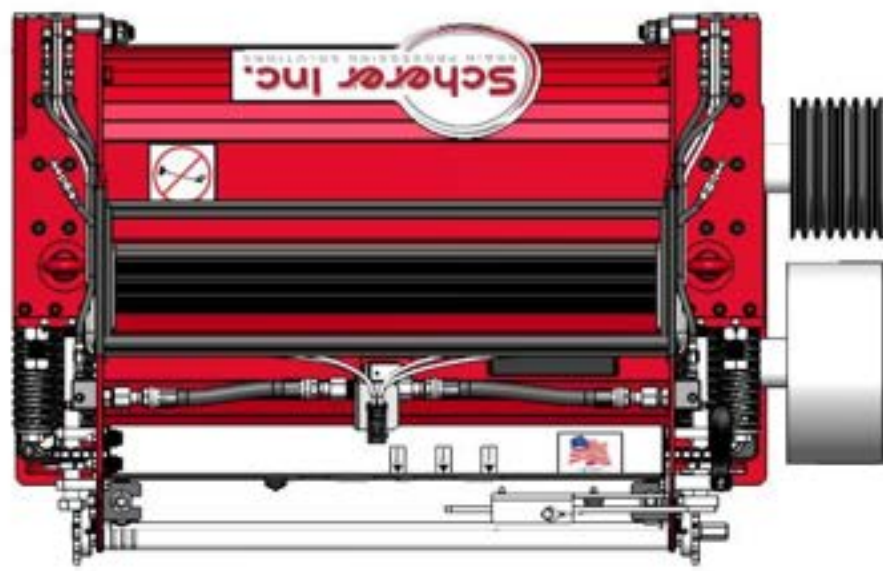
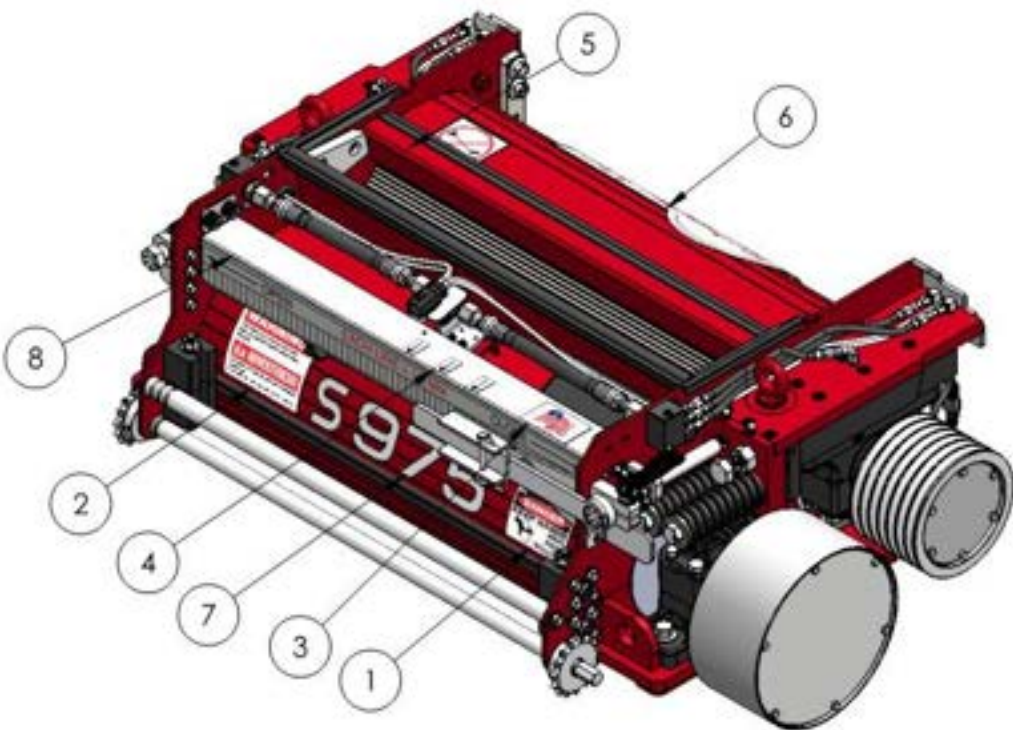

ITEM NO.	PART NUMBER	DESCRIPTION	QTY.
1	DEC1001	DANGER : ROLLERS	1
2	DEC1002	WARNING	1
3	DEC1003	MADE IN AMERICA	1
4	DEC1013	ROLL GAP POINTERS	3
5	DEC1050	DO NOT POWERWASH	1
6	DEC1066	SCHERER KP DECAL	1
7	DEC1070	S975	1
8	HPST1056	ROLL GAP REFERENCE STICKER	1

Scherer Equipped Decal



Accessory Parts



A0006 - 1 Gallon KP Oil



A006.5 - 5 Gallon KP Oil

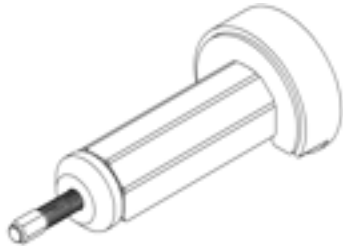

A0022 - 60mm Bearing Puller



ASM10501 - Bearing Puller Tip



A0003 - KP Lifting Chain



A0011 - Laser Alignment Tool



A0021 - Bearing Heater



A0008 - Laser Temp. Gun